

Microarchitectural Attacks

Michael Schwarz

November 22, 2019

www.iaik.tugraz.at

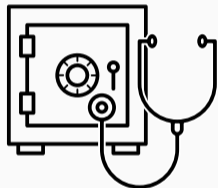

- Safe software infrastructure does not mean safe execution
- Information leaks because of the **underlying hardware**
- Exploit **unintentional information leakage by side-effects**



Power consumption



Execution time



CPU caches



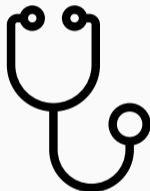





- Side channels also exist in **software**
- Can be used for attacks
- Usually **timing differences**

- Trivial approach: Compare each digit until a difference





```
int check_pin(char* input) {
    const char* correct = "1234";
    for(int i = 0; i < 4; i++) {
        if(correct[i] != input[i]) {
            // digit differs, abort
            return ERROR;
        }
    }
    // PIN is correct
    return OK;
}
```

- Measuring the **execution times** for different PINs

PIN	Time
0000	
1000	
2000	
3000	
...	...

- If digit is **correct**, next digit is checked → **longer** execution time
- 10 tries (maximum) to get a digit

- Measuring the execution times for different PINs

PIN	Time
1000	
1100	
1200	
1300	
...	...

- Repeat for every digit
- Longest** execution time reveals correct digit



- Maximum 10 measurements per digit
- 4-digit PIN: 40 tries
- Brute force: 10 000 tries
- Simple side channel reduces tries by **factor 250**

- Many functions can be implemented with **constant runtime**

```
int check_pin(char* input) {
    const char* correct = "1234";
    int same = 0;
    for(int i = 0; i < 4; i++) {
        same |= correct[i] - input[i];
    }
    return (same == 0);
}
```

- Sometimes, there is still a side channel in the **hardware**

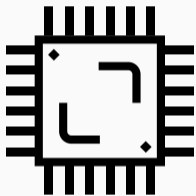

- Instruction Set Architecture (ISA) is an abstract model of a computer (x86, ARMv8, SPARC, ...)
- Serves as the **interface** between hardware and software
- Microarchitecture is an **actual implementation** of the ISA



- Modern CPUs contain multiple **microarchitectural elements**

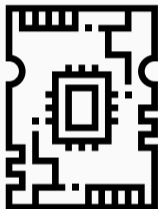

Caches and buffer



Predictor



- **Transparent** for the programmer
- **Optimize** program execution
- Timing differences → side-channel leakage

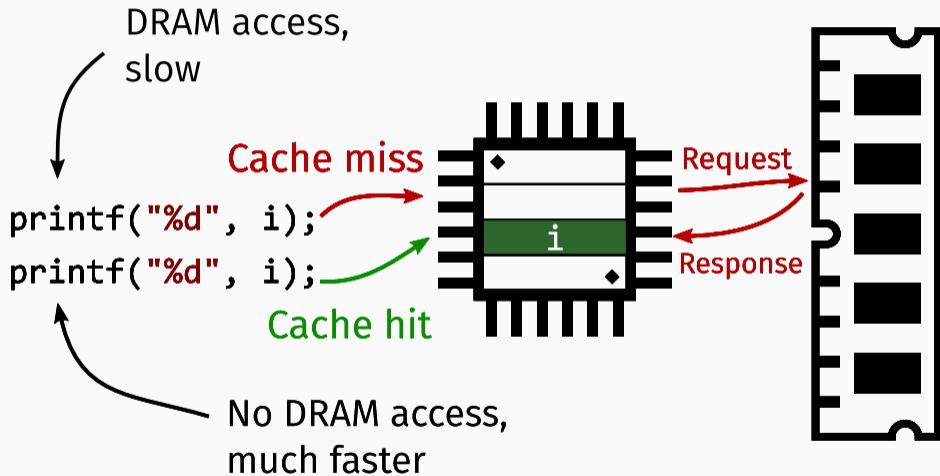

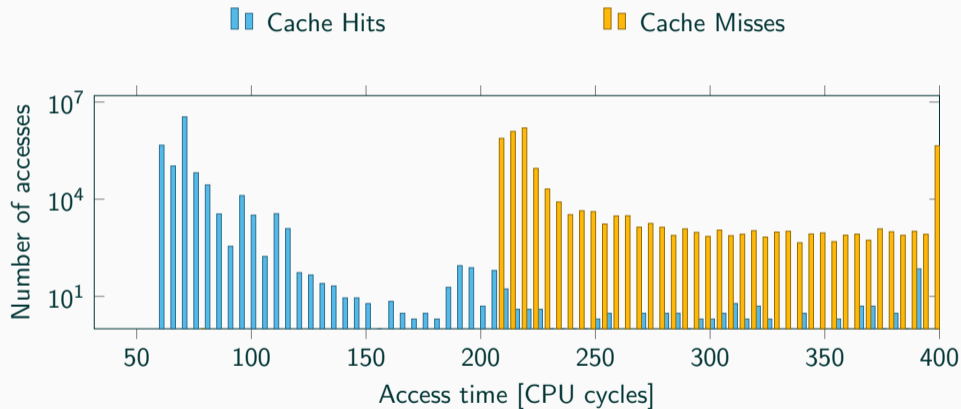

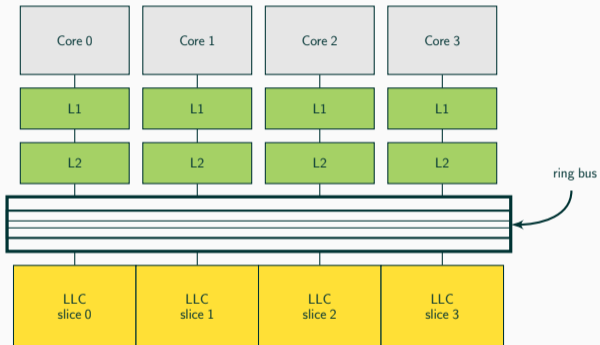

- L1 and L2 are private
- Last-level cache is
 - divided into slices
 - shared across cores
 - inclusive

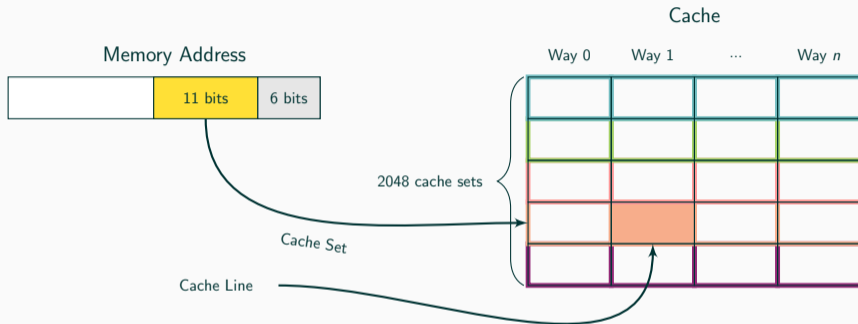

- Location in cache depends on the physical address of data
- Bits 6 to 16 determine the **cache set**
- A cache set has multiple **ways** to store the data
- A way inside a cache set is a **cache line**, determined by the **cache replacement policy**

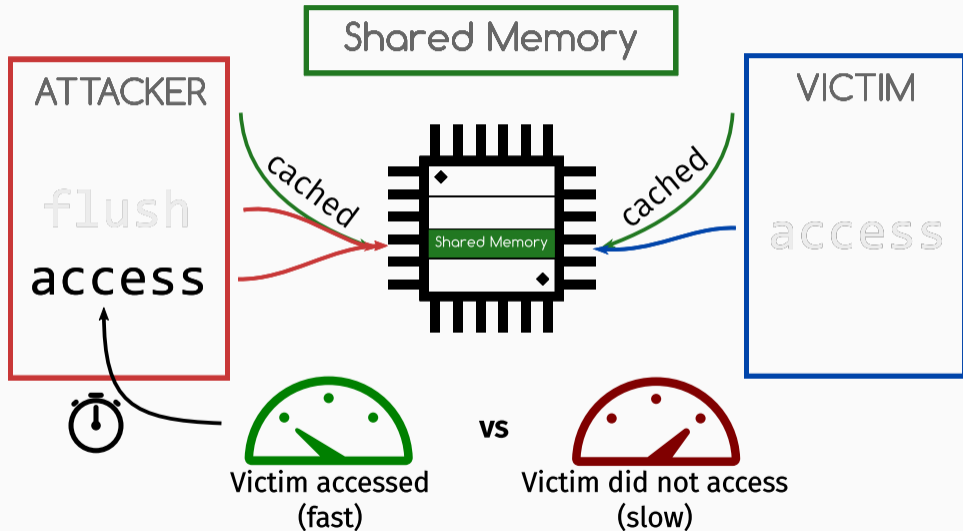

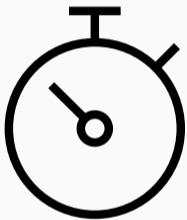

```
struct shared_data [256];  
[...]  
return shared_data [84];  
[...]
```

- Flush+Reload over memory locations



- Accessed index results in **faster access time**

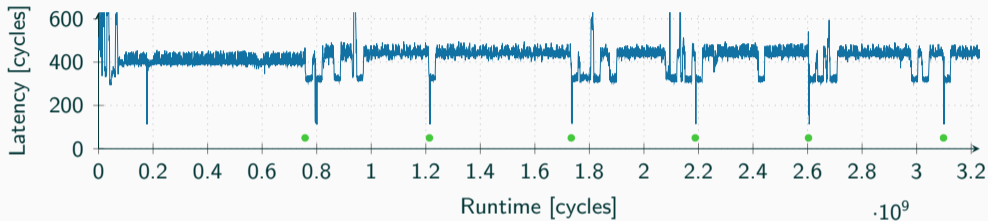

- Key presses trigger code execution in shared library (e.g., `libgdk`)
- Flush+Reload does not reveal actual key, only **time difference** between keys
- → Recover text with machine learning

string

/	p	a	t	h	/	f	i	l	e	\0	X	p	a	y	l	o	a	d	\0
---	---	---	---	---	---	---	---	---	---	----	---	---	---	---	---	---	---	---	----

←————— length length —————→

Thread 1

```
strcpy(string, "/path/file\0payload");
```

```
open(string, O_CREAT);
```

```
// <switch to kernel>
```

```
int len = strlen(string);
```

```
char* local = malloc(len + 1);
```

```
strcpy(local, string);
```

```
// <memory corruption>
```

Thread 2

```
string[10] = 'X';
```

schedule
schedule

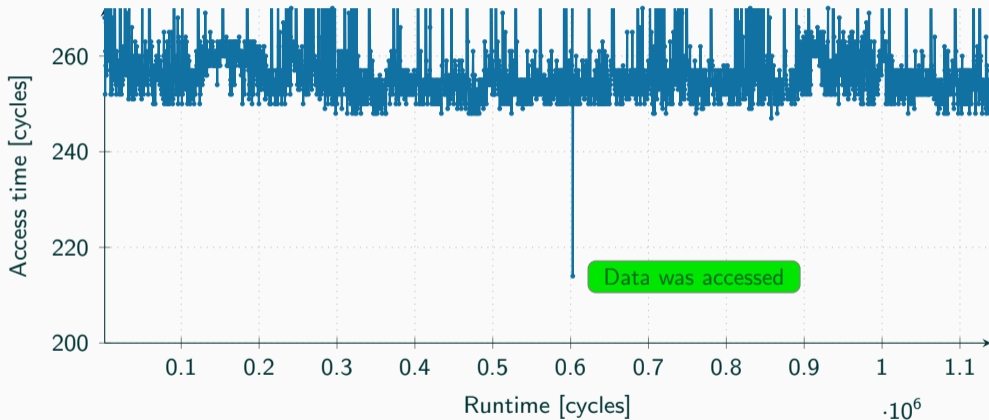

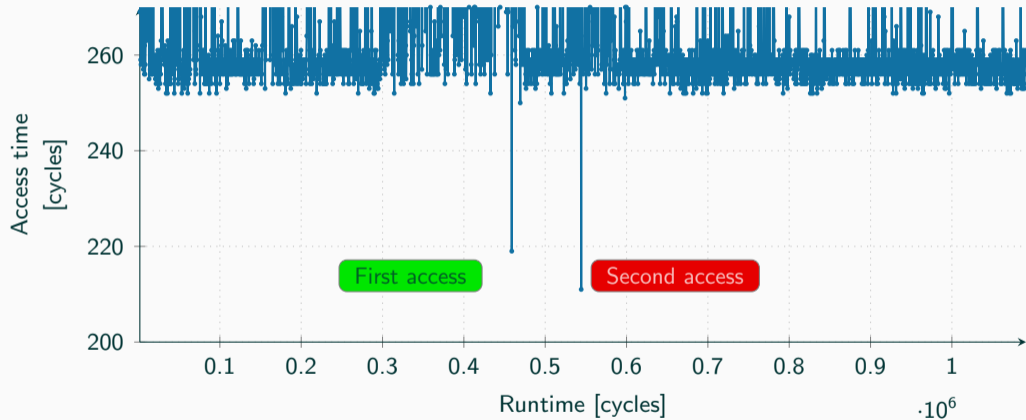

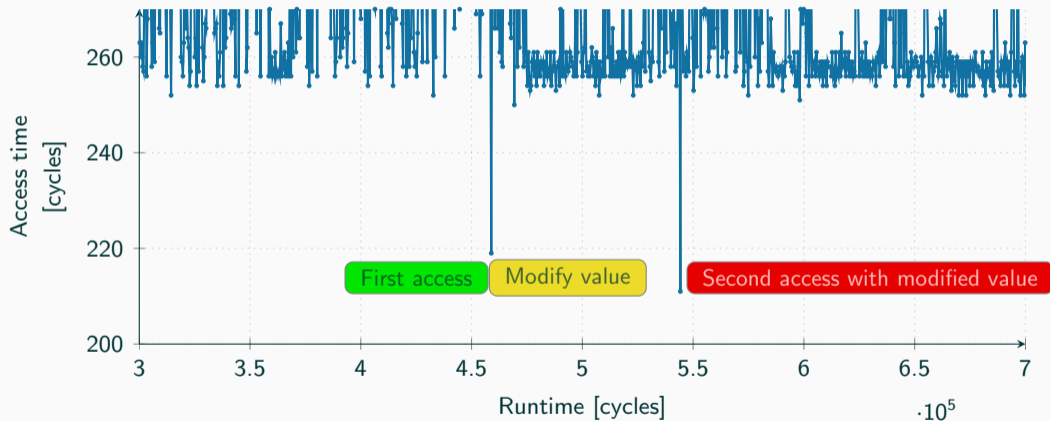

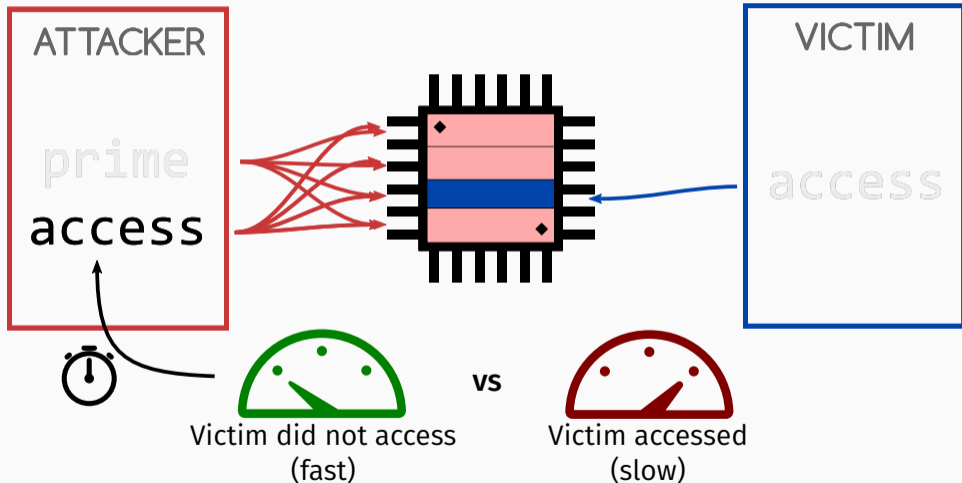

$$M = C^d \pmod n$$

$$\text{Result} = \underbrace{\text{Result} \times \text{Result}}_{\text{square}} \times \underbrace{C}_{\text{multiply}}$$

Raw Prime+Probe trace...



...processed with a simple moving average...

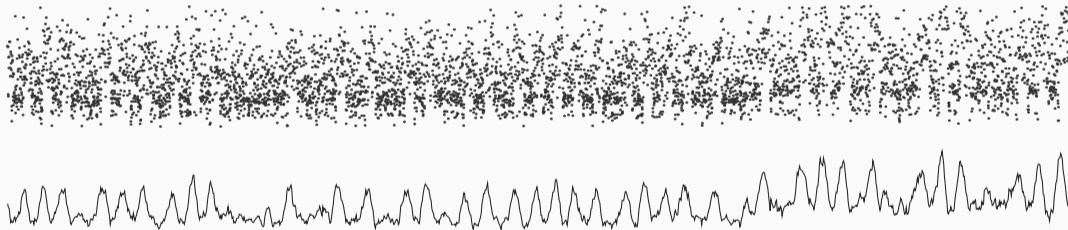

...allows to clearly see the bits of the exponent

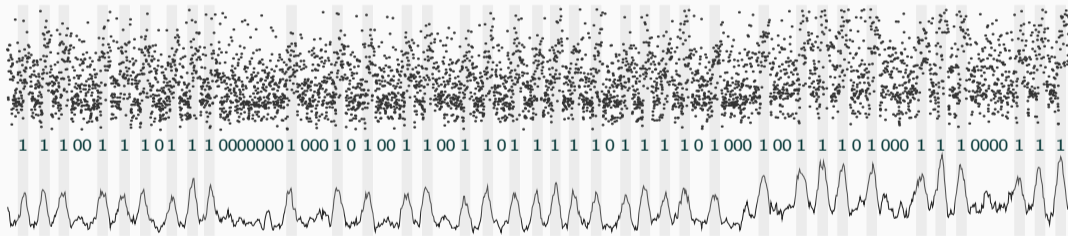

Intel claiming it is
out of scope



Side-channel Researcher





What is a **covert channel**?

- Two programs would like to communicate but are **not allowed** to do so
 - either because there is no communication channel...
 - ...or the channels are monitored and programs are stopped on communication attempts
- Use **side channels** and stay stealthy



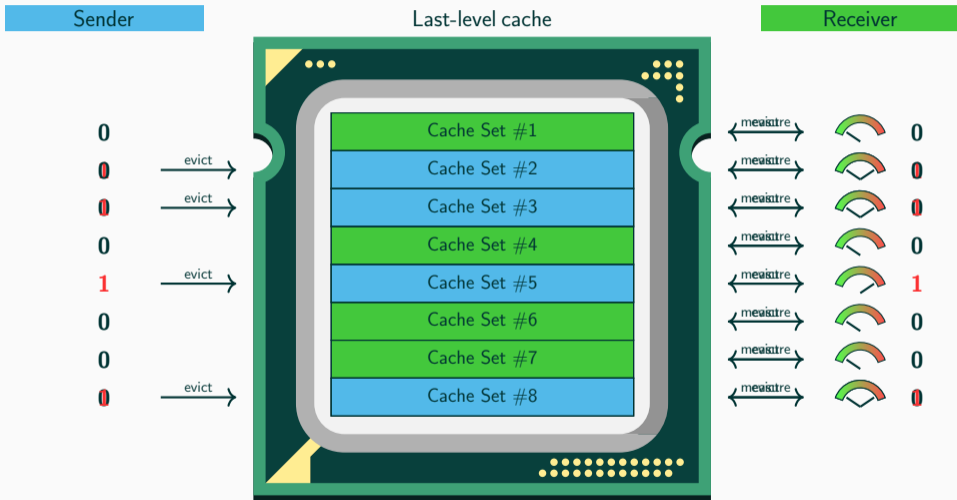

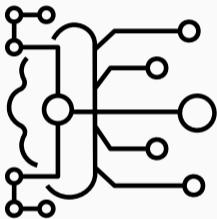

- Multiple other elements with timing differences
 - TLB
 - DRAM
 - Memory Bus
 - Execution Units
 - ...
- Many side-channel attacks exploiting them



- So far, only memory accesses
- **Meta data**, no actual data
- Sufficient to **deduce** data...
- ...if memory accesses are **secret dependent**

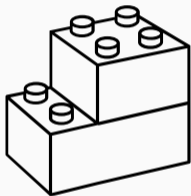

- Side channels can be part of an attack
- Also for **conventional** memory corruption **attacks**
- Side channels as **building blocks**
 - Required information (e.g., break ASLR)
 - Additional information (e.g., length of password)
 - Covertly transmit information
 - **Transient-execution attacks**



- Meltdown is a CPU vulnerabilities
- Discovered in 2017 by multiple independent teams
- Allows breaking the process isolation
- Side-channel attack is a core building block

- Kernel is isolated from user space
- This **isolation** is a combination of hardware and software
- User applications cannot access anything from the kernel
- There is only a well-defined interface → **syscalls**

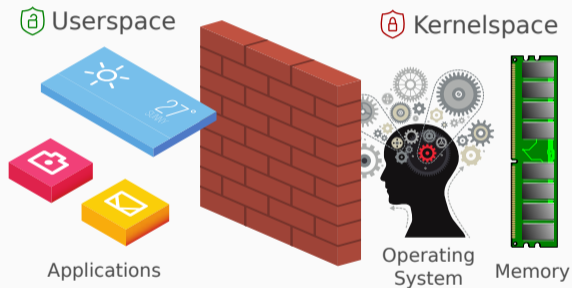

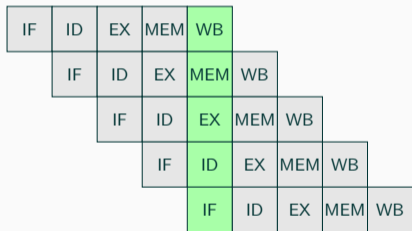

- Instructions are...
 - **fetched** (IF) from the L1 Instruction Cache
 - **decoded** (ID)
 - **executed** (EX) by execution units
- Memory **access** is performed (MEM)
- Architectural **register file** is **updated** (WB)



- Instructions are executed **in-order**
- Pipeline **stalls** when stages are not ready
- If data is **not cached**, we need to wait





Parallelize

Dependency

```
int width = 10, height = 5;

float diagonal = sqrt(width * width
                      + height * height);

int area = width * height;

printf("Area %d x %d = %d\n", width, height, area);
```

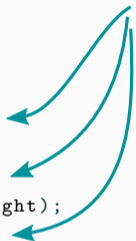

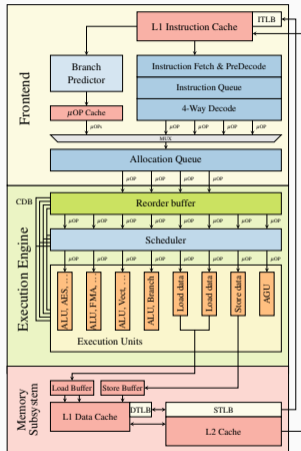

Instructions are

- fetched and decoded in the **front-end**
- dispatched to the **backend**
- processed by **individual execution units**

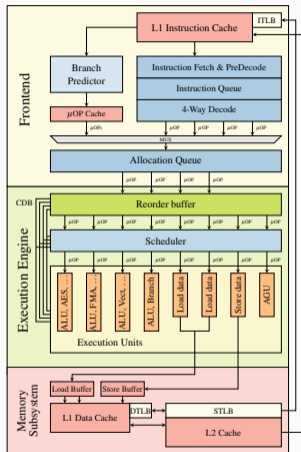

Instructions

- are executed **out-of-order**
- wait until their **dependencies are ready**
 - Later instructions might execute prior earlier instructions
- **retire in-order**
 - State becomes architecturally visible
- **Exceptions** are checked during retirement
 - Flush pipeline and recover state

The state does not become **architecturally visible** but ...





- New code

```
*(volatile char*) 0;  
array[84 * 4096] = 0;
```

- volatile because compiler was not happy

```
warning: statement with no effect [-Wunused-value]  
    *(char*)0;
```

- Static code analyzer is still not happy

```
warning: Dereference of null pointer  
    *(volatile char*)0;
```



- Flush+Reload over all pages of the array

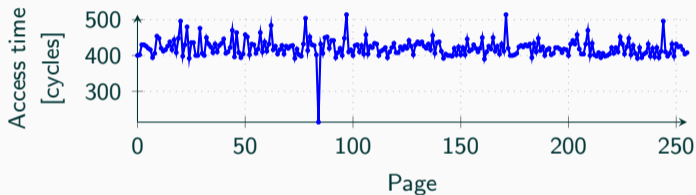

- “Unreachable” code line was **actually executed**
- Exception was only thrown **afterwards**



- Out-of-order instructions **leave microarchitectural traces**
 - We can see them for example in the cache
- Give such instructions a name: **transient instructions**
- We can indirectly observe the **execution of transient instructions**





- Add another **layer of indirection** to test

```
char data = *(char*) 0xffffffff81a000e0;  
array[data * 4096] = 0;
```

- Then check whether any part of array is **cached**

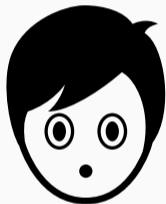

- Flush+Reload over all pages of the array



- **Index** of cache hit reveals **data**
- **Permission check** is in some cases **not fast enough**

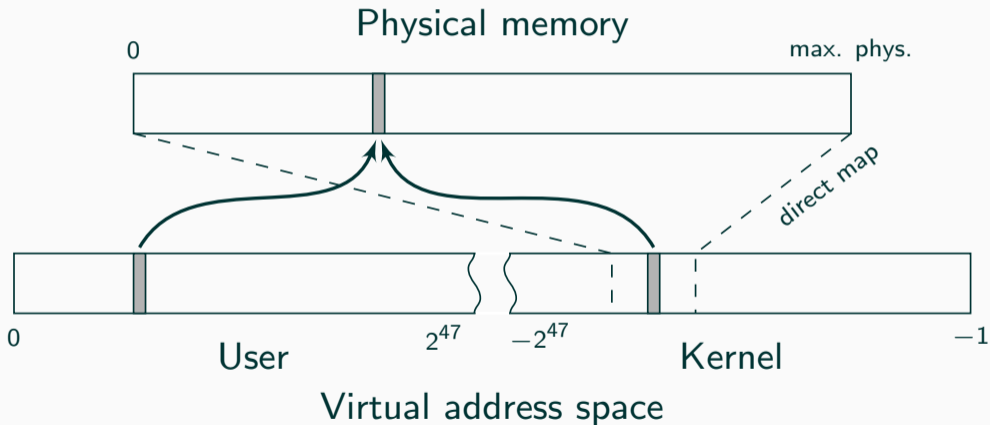



- Using **out-of-order execution**, we can read **data at any address**
- **Index** of cache hit reveals **data**
- **Permission check** is in some cases **not fast enough**
- **Entire physical memory** is typically accessible through kernel space

I SHIT YOU NOT

**THERE WAS KERNEL MEMORY ALL
OVER THE TERMINAL**





**There are no bugs,
just happy little accidents**





- Meltdown is a whole **category of vulnerabilities**
- Not only the user-accessible check
- Looking closer at the check...

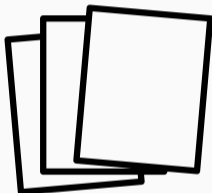

- CPU uses **virtual address spaces** to isolate processes
- Physical memory is organized in **page frames**
- Virtual memory pages are **mapped** to page frames **using page tables**

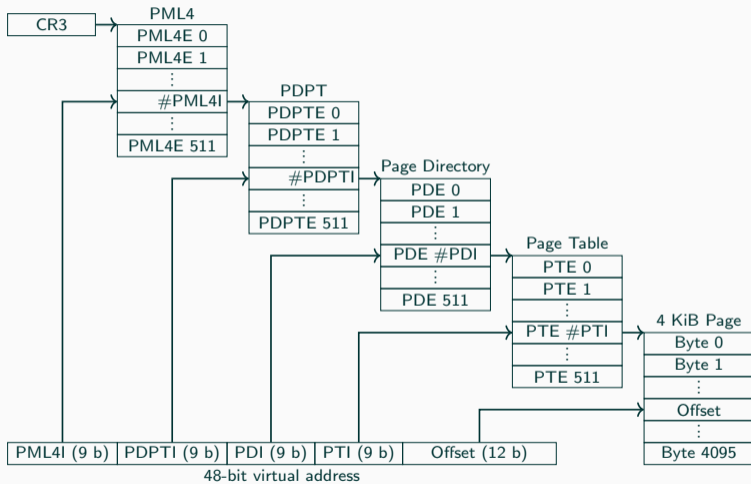

P	RW	US	WT	UC	R	D	S	G	Ignored	
Physical Page Number										
									Ignored	X

- User/Supervisor bit defines in which **privilege level** the page can be accessed

P	RW	US	WT	UC	R	D	S	G	Ignored	
Physical Page Number										
									Ignored	X

- **Present** bit is the next obvious bit



- An even **worse** bug → Foreshadow-NG/L1TF
- Exploitable from **VMs**
- Allows **leaking** data from the **L1** cache
- Same mechanism as Meltdown
- Just a **different bit** in the PTE

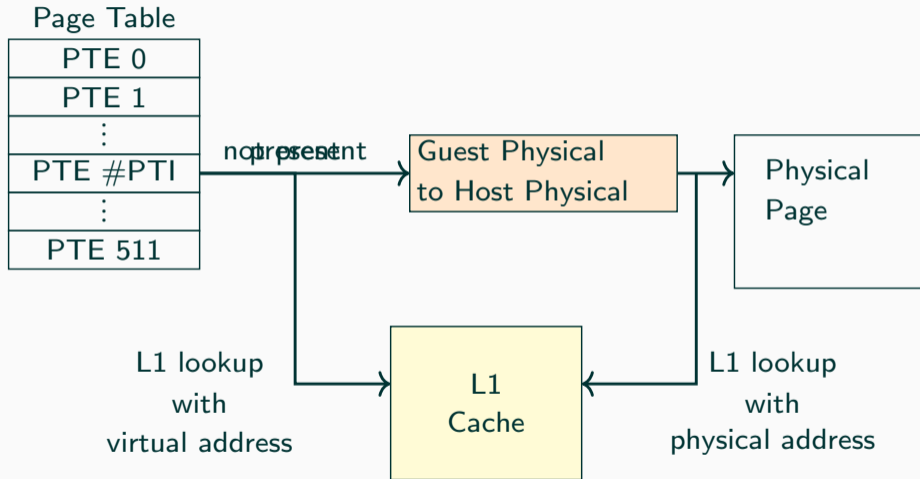



- KAISER/KPTI/KVA does not help
- Only **software workarounds**
 - **Flush L1** on VM entry
 - Disable **HyperThreading**
- Workarounds might not be complete

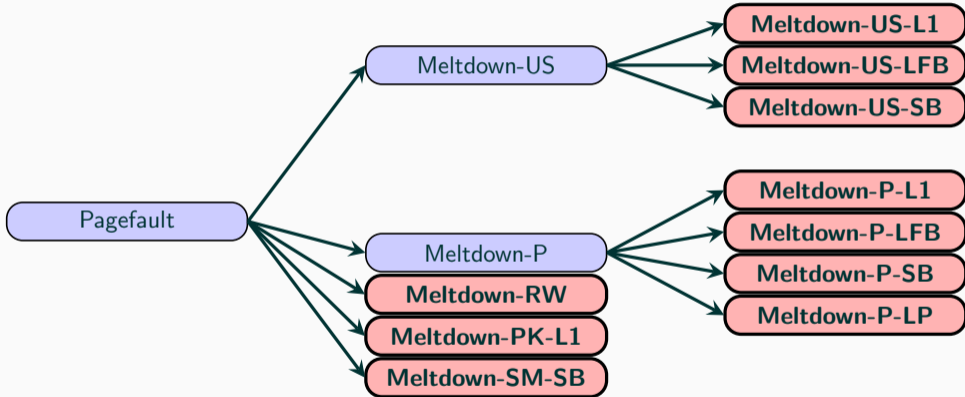

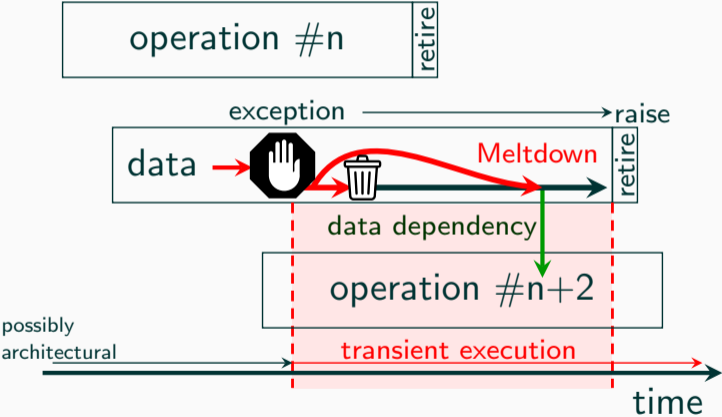

YOU GET A FAULT



**AND YOU GET A FAULT.
EVERYONE GETS A FAULT**

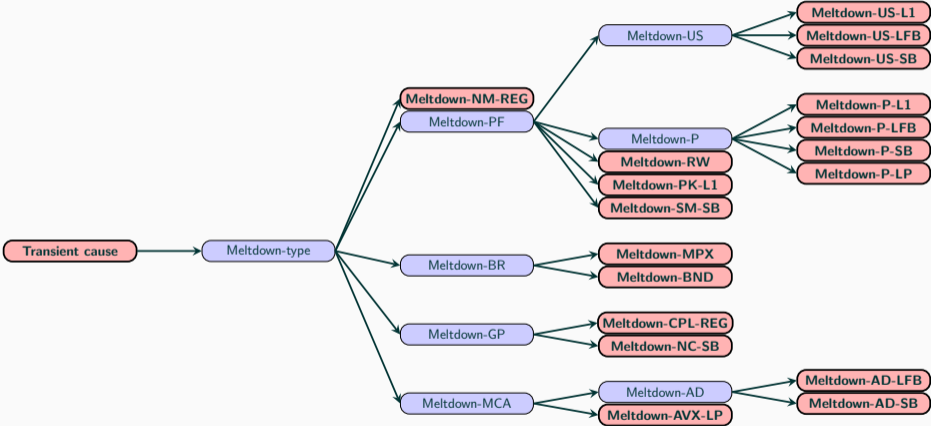

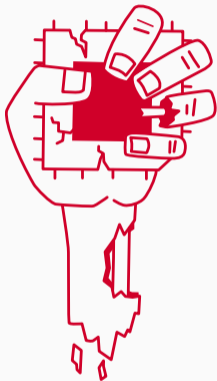

- Leaks from the **fill buffer**
- Crosses all privilege boundaries (Kernel, VM, SGX)
- Explored microcode assists as new type of faults
- Disadvantage: **minimal control** over leaked data



- Meltdown is **not** a fully **solved** issue
- The tree is extensible
- **More** Meltdown-type **issues** to come
- Silicon fixes might not be complete



- Meltdown not the only **transient execution attacks**
- **Spectre** is a second class of transient execution attacks
- Instead of faults, exploit control (or data) **flow predictions**



- CPU tries to predict the future (branch predictor), ...
 - ...based on events learned in the past
- **Speculative execution** of instructions
- If the prediction was correct, ...
 - ...very fast
 - otherwise: Discard results

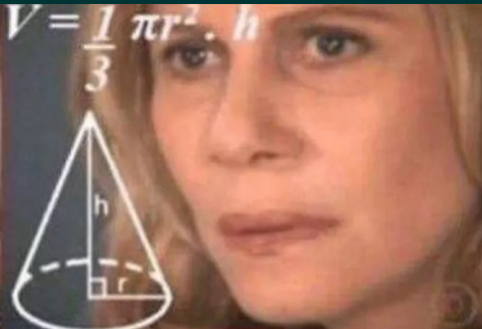

$$V = \frac{1}{3} \pi r^2 \cdot h$$

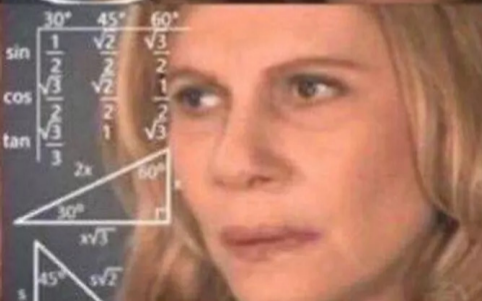
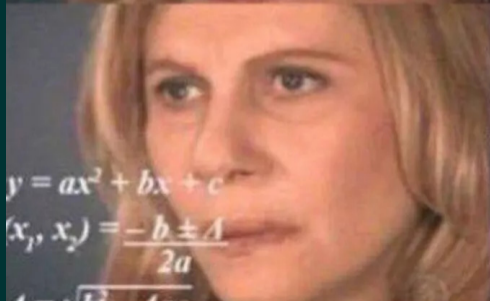

$$y = ax^2 + bx + c$$
$$(x_1, x_2) = \frac{-b \pm \sqrt{b^2 - 4ac}}{2a}$$

	30°	45°	60°
sin	$\frac{1}{2}$	$\frac{\sqrt{2}}{2}$	$\frac{\sqrt{3}}{2}$
cos	$\frac{\sqrt{3}}{2}$	$\frac{\sqrt{2}}{2}$	$\frac{1}{2}$
tan	$\frac{1}{\sqrt{3}}$	1	$\sqrt{3}$

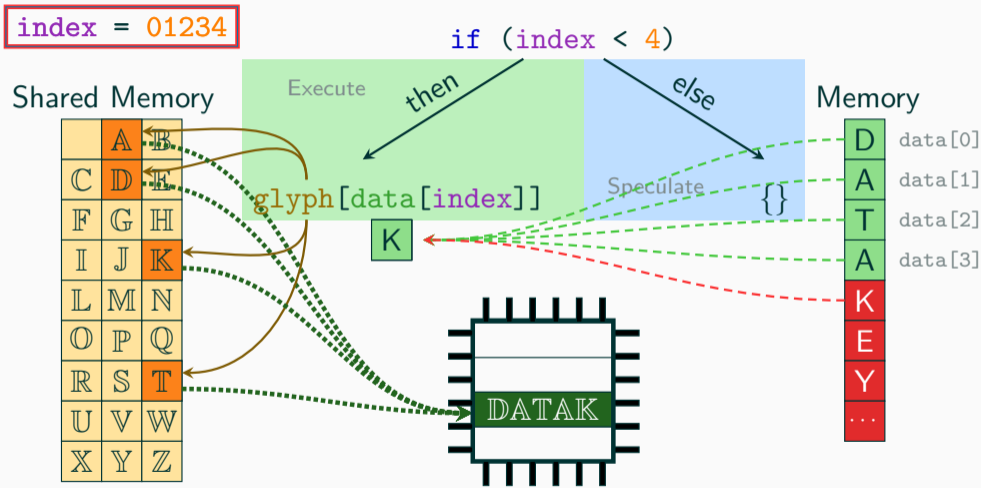

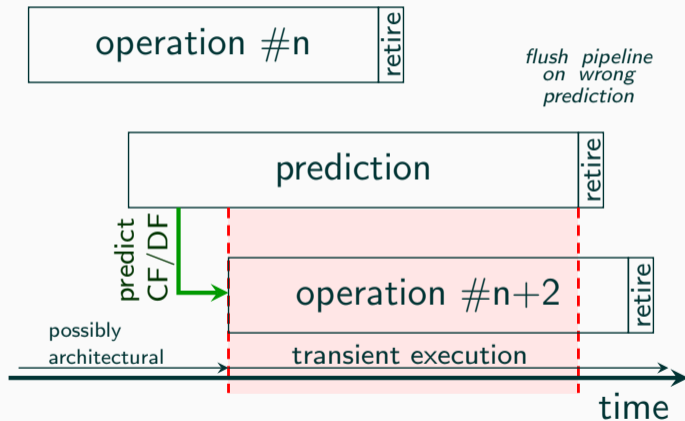



- Many predictors in modern CPUs
 - Branch taken/not taken (PHT)
 - Call/Jump destination (BTB)
 - Function return destination (RSB)
 - Load matches previous store (STL)
- Most are even shared among processes

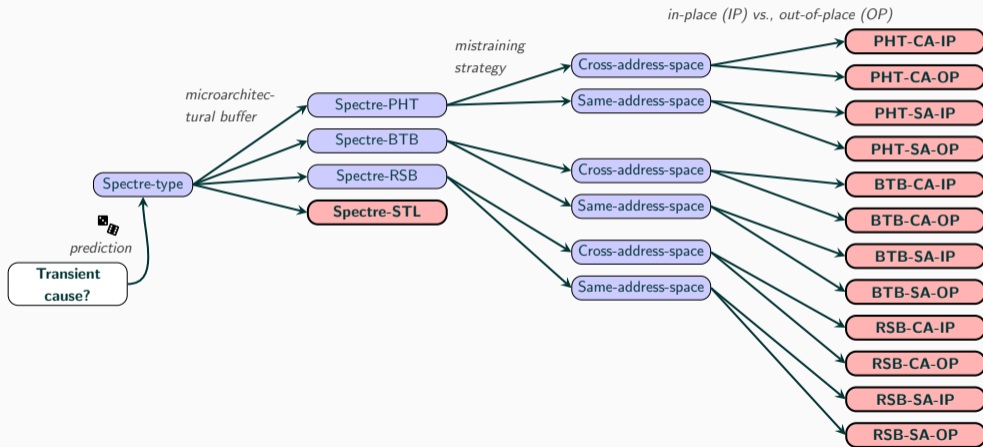



- Spectre is **not a bug**
 - It is an useful **optimization**
- Cannot simply fix it (as with Meltdown)
- **Workarounds** for critical code parts

Linux 4.19.4 & 4.14.83 Released With STIBP Code Dropped

Written by Michael Larabel in Linux Kernel on 24 November 2018 at 09:00 AM EST. 6 Comments



On Friday marked the release of the Linux 4.19.4 kernel as well as 4.14.83 and 4.9.139.

Greg Kroah-Hartman issued this latest round of stable point releases as basic maintenance updates. While these point releases don't tend to be too notable and generally go unmentioned on Phoronix, this round is worth pointing out since 4.19.4 and 4.14.83 are the releases that end up reverting the STIBP behavior that applied Single Thread Indirect Branch Predictors to all processes on supported systems. That is what was introduced in Linux 4.20 and then back-ported to the 4.19/4.14 LTS branches, which in turn hurt the performance a lot. So for now the code is removed.

As covered yesterday, there is improved STIBP code on the way for Linux 4.20 that by default just apply STIBP to SECCOMP threads and processes requesting it via prctl() but otherwise is off by default (that behavior can also be changed via kernel parameters).

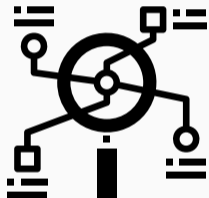

- Current mitigations are either **incomplete or cost performance**
- More **research** required
- Both on **attacks and defenses**
- Efficient defenses only possible when attacks are known

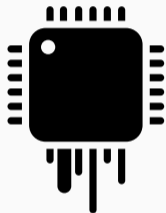

- Side channels so far
 - leak meta data
 - covertly transmit data
- As a building block
 - leak data
- What about modifying data?

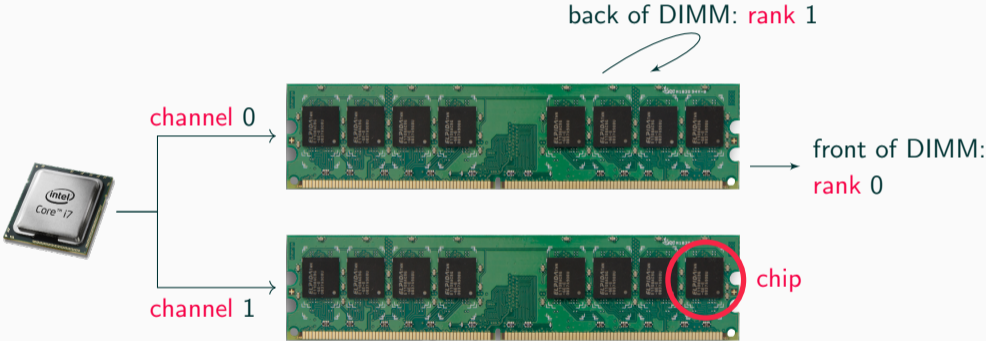

chip

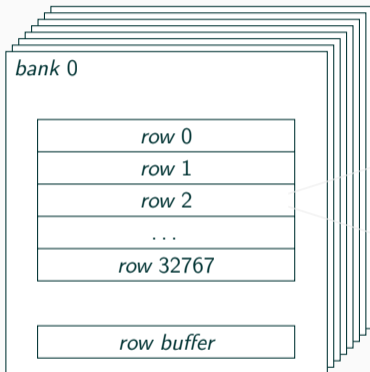

64k cells
1 capacitor,
1 transistor each

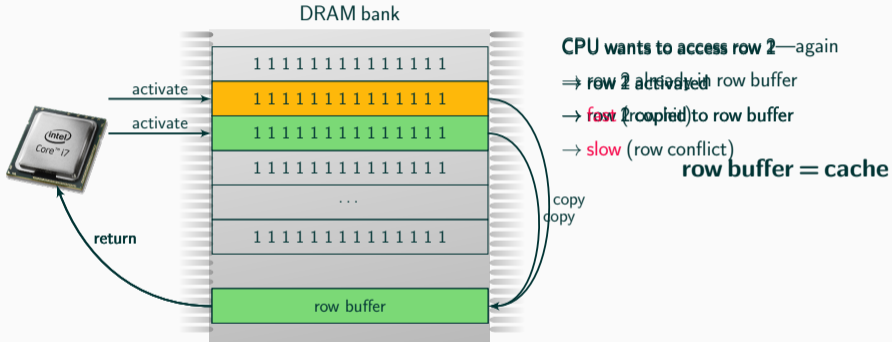

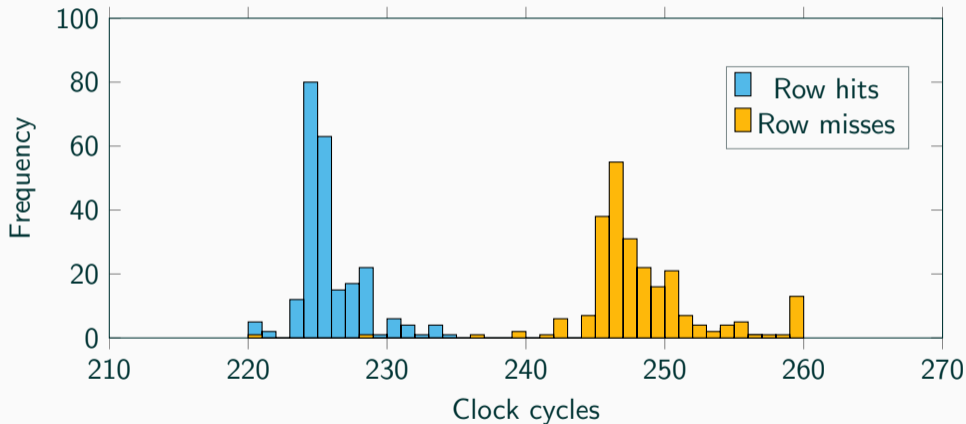

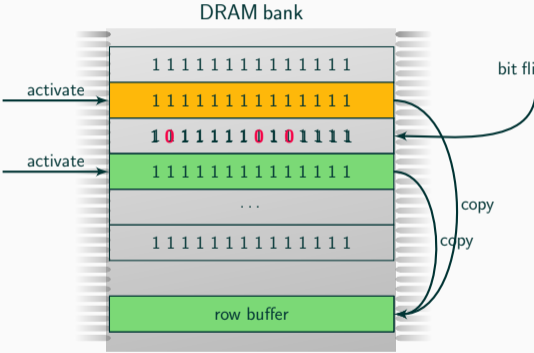

Cells leak faster upon proximate accesses → Rowhammer



- 85% affected (estimation 2014)
- 52% affected (estimation 2015)



- First believed to be safe
- We showed bit flips in 2016
- 67% affected (estimation 2016)



- Single bit flips allow
 - modifying instructions
 - breaking cryptography
 - changing permissions
 - crashing systems
 - ...
- In software, no permissions required

- Program containing **conditional jump** after password check:
je 80486c1 <check_password+0x44>
- Machine code is
0x74 0x07 = 0b01110100 0b00000111



- **One bit changed**: 0b0111010**1** 0b00000111 = 0x75 0x07 =
jne 80486c1 <check_password+0x44>
- Now only **wrong** passwords work → demonstrated on sudo



- More attacks **exploiting performance optimizations** in hardware
 - **New variants** are disclosed frequently

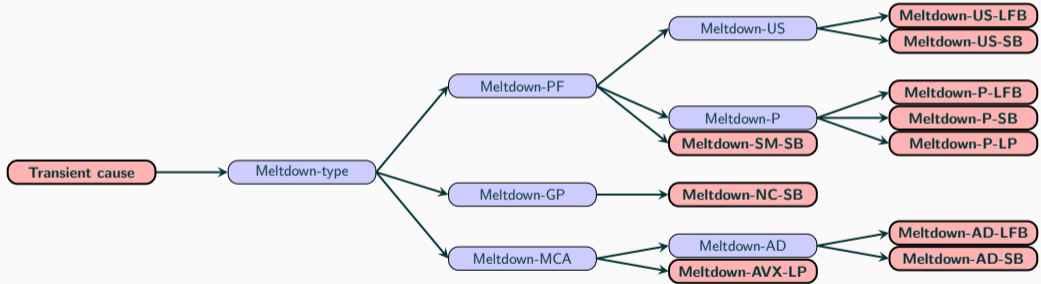

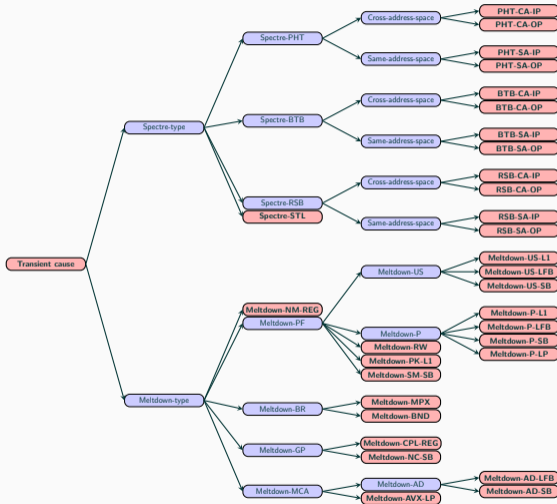

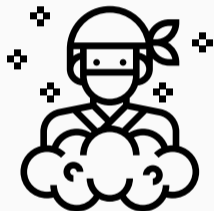

- **Transient Execution Attacks** are...
 - ...a **novel class** of attacks
 - ...extremely **powerful**
 - ...only at the **beginning**
- Many optimizations introduce side channels → now exploitable

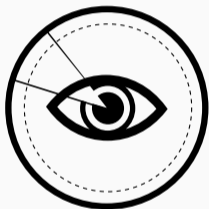

A **unique chance** to

- rethink processor design
- grow up, like other fields (car industry, construction industry)



- Optimizations in hardware often lead to side channels
- Unknown and novel side channels are likely to exist
- Next to no permissions required for attacks
- Building countermeasures is extremely hard

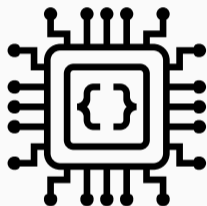

- Only an **overview** over some attacks
- Many more side-channel attacks
- Also some defenses, especially for crypto
- Master course: **Embedded Security**
- Talks from our group on YouTube: “InfoSec @ TU Graz”

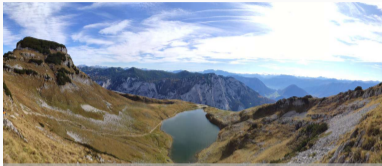

IAIK  TU
Graz
Technical University of Applied Sciences

Bachelor@IAIK 2020
Themen.Vorstellung.

**+ Student Research
Awards 2019**

Freitag 29. Nov., 12:00 - 13:00
IAIK-Foyer
Inffeldgasse 16a, Erdgeschoß.

www.iaik.tugraz.at

- Looking for a **bachelor thesis**?
- Our institute presents many topics
- **Awards** for students who contributed to **publications**

Any Questions?