

# Operating Systems

File Systems

**Daniel Gruss**

2023-10-08









Storage Device

0 TB

18 TB

# Storage Device

*How to organize this?*

0 TB

18 TB



- User does not want to see, know and understand
    - where and
    - ? how
  - data is stored
  - must be able to refer to data
- we need names

















Bild	5117 Produkte	Bewertung (Anzahl)	Testberichte	Angebote	LZ	Preis*  (pro GiB)
	<p><a href="#">Samsung RDIMM 16GB, DDR3L-1600, CL11-11-11, reg ECC (M393B2G70BH0-YK0)</a></p> <p>Typ: DDR3L RDIMM 240-Pin, reg ECC • Takt: 1600MHz • Module: 1x 16GB • JEDEC: PC3L-12800R • Ranks/Bänke: dual rank, x4 • CAS Latency CL: 11 (entspricht ~13.75ns) • Row-to-Column Delay tRCD: 11 (entspricht ~13.75ns) • Row Precharge Time tRP: 11 ...</p>	(zu wenige)		5		ab € 29,90 (€ 1,869/GB)
	<p><a href="#">Samsung RDIMM 16GB, DDR3L-1600, CL11-11-11, reg ECC (M393B2G70DB0-YK0)</a></p> <p>Typ: DDR3L RDIMM 240-Pin, reg ECC • Takt: 1600MHz • Module: 1x 16GB • JEDEC: PC3L-12800R • Ranks/Bänke: dual rank, x4 • CAS Latency CL: 11 (entspricht ~13.75ns) • Row-to-Column Delay tRCD: 11 (entspricht ~13.75ns) • Row Precharge Time tRP: 11 ...</p>	(zu wenige)		36		ab € 35,00 (€ 2,188/GB)
	<p><a href="#">Samsung LRDIMM 32GB, DDR3-1866, CL13-13-13, ECC (M386B4G70DM0-CMA)</a></p> <p>Typ: DDR3 LRDIMM 240-Pin, ECC • Takt: 1866MHz • Module: 1x 32GB • JEDEC: PC3-14900L • Ranks/Bänke: quad rank, x4 • CAS Latency CL: 13 (entspricht ~13.93ns) • Row-to-Column Delay tRCD: 13 (entspricht ~13.93ns) • Row Precharge Time tRP: 13 ...</p>	(zu wenige)		6		ab € 74,25 (€ 2,320/GB)
	<p><a href="#">Samsung RDIMM 32GB, DDR4-2133, CL15-15-15, reg ECC (M393A4K40BB0-CPB)</a></p> <p>Typ: DDR4 RDIMM 288-Pin, reg ECC • Takt: 2133MHz • Module: 1x 32GB • JEDEC: PC4-17000R • Ranks/Bänke: dual rank, x4 • CAS Latency CL: 15 (entspricht ~14.06ns) • Row-to-Column Delay tRCD: 15 (entspricht ~14.06ns) • Row Precharge Time tRP: 15 ...</p>	(zu wenige)		12		ab € 79,00 (€ 2,469/GB)
	<p><a href="#">Patriot Signature Line DIMM 8GB, DDR4-2666, CL19-19-19-43 (PSD48G266681)</a></p> <p>Typ: DDR4 DIMM 288-Pin • Takt: 2666MHz • Module: 1x 8GB • JEDEC: PC4-21300U • Ranks/Bänke: single rank • CAS Latency CL: 19 (entspricht ~14.25ns) • Row-to-Column Delay tRCD: 19 (entspricht ~14.25ns) • Row Precharge Time tRP: 19 (entspricht ...</p>	(zu wenige)		26		ab € 19,90 (€ 2,487/GB)
	<p><a href="#">Patriot Signature Line ohne Kühler DIMM 8GB, DDR3-1600, CL11 (PSD38G16002)</a></p> <p>Typ: DDR3 DIMM 240-Pin • Takt: 1600MHz • Module: 1x 8GB • JEDEC: PC3-12800U • CAS Latency CL: 11 (entspricht ~13.75ns) • Spannung: 1.5V • Modulhöhe: 30mm • Gehäuse: N/A • Beleuchtung: N/A • Besonderheiten: Standard-SPD • Garantie: (bitte ...</p>	(zu wenige)		15		ab € 19,99 (€ 2,499/GB)
	<p><a href="#">Patriot Signature Line SO-DIMM 8GB, DDR3L-1600, CL11 (PSD38G1600L2S)</a></p> <p>Typ: DDR3L SO-DIMM 204-Pin • Takt: 1600MHz • Module: 1x 8GB • JEDEC: PC3L-12800S • CAS Latency CL: 11 (entspricht ~13.75ns) • Spannung: 1.35V • Modulhöhe: 30mm • Gehäuse: N/A • Beleuchtung: N/A • Besonderheiten: Standard-SPD • Garantie: (bitte ...</p>	(zu wenige)		16		ab € 19,99 (€ 2,499/GB)
	<p><a href="#">Samsung RDIMM 8GB, DDR3L-1333, CL9-9-9, reg ECC (M393B1K70DH0-YH9)</a></p> <p>Typ: DDR3L RDIMM 240-Pin, reg ECC • Takt: 1333MHz • Module: 1x 8GB • JEDEC: PC3L-10667R • Ranks/Bänke: dual rank • CAS Latency CL: 9 (entspricht ~13.50ns) • Row-to-Column Delay tRCD: 9 (entspricht ~13.50ns) • Row Precharge Time tRP: 9 (entspricht ...</p>	(zu wenige)		13		ab € 20,00 (€ 2,500/GB)



























Bild	2700 Produkte	Bewertung (Anzahl)	Testberichte	Angebote	LZ	Preis* (pro TB)
	<a href="#">Patriot Burst Elite 1.92TB, SATA (PBE192TS25SSDR)</a> Bauform: Solid State Drive (SSD) • Formfaktor: 2.5" • Schnittstelle: SATA 6Gb/s • Lesen: 450MB/s • Schreiben: 320MB/s • IOPS 4K lesen/schreiben: 40k/40k • Speichermodule: 3D-NAND QLC • TBW: 800TB • Zuverlässigkeitsprognose: 2 Mio. Stunden (MTBF) ...	(zu wenige)	1 Testbericht	11	■	ab € 103,90 (€ 54,115/TB)
	<a href="#">Intenso PCIe PREMIUM SSD 1TB, M.2 (3835460)</a> Bauform: Solid State Module (SSM) • Formfaktor: M.2 2280 • Schnittstelle: M.2/M-Key (PCIe 3.0 x4) • Lesen: 2100MB/s • Schreiben: 1700MB/s • Speichermodule: 3D-NAND TLC • TBW: 600TB • Protokoll: NVMe 1.3 • Leistungsaufnahme: keine Angabe ...	(zu wenige)		40	■	ab € 55,99 (€ 55,990/TB)
	<a href="#">Intenso Top Performance SSD 2TB, SATA (3812470)</a> Bauform: Solid State Drive (SSD) • Formfaktor: 2.5" • Schnittstelle: SATA 6Gb/s • Lesen: 520MB/s • Schreiben: 500MB/s • Protokoll: AHCI • Leistungsaufnahme: keine Angabe (maximal), keine Angabe (Betrieb), keine Angabe (Leerlauf), keine Angabe ...	(zu wenige)		41	■	ab € 117,03 (€ 58,515/TB)
	<a href="#">Patriot P210 1TB, SATA (P210S1TB25)</a> Bauform: Solid State Drive (SSD) • Formfaktor: 2.5" • Schnittstelle: SATA 6Gb/s • Lesen: 520MB/s • Schreiben: 430MB/s • IOPS 4K lesen/schreiben: 50k/50k • Speichermodule: 3D-NAND (verschiedene Bestückungen möglich) • TBW: keine Angabe ...	(zu wenige)	1 Testbericht	35	■	ab € 58,89 (€ 58,890/TB)
	<a href="#">Intenso Top Performance SSD 1TB, SATA (3812460)</a> Bauform: Solid State Drive (SSD) • Formfaktor: 2.5" • Schnittstelle: SATA 6Gb/s • Lesen: 520MB/s • Schreiben: 500MB/s • Protokoll: AHCI • Leistungsaufnahme: keine Angabe (maximal), keine Angabe (Betrieb), keine Angabe (Leerlauf), keine Angabe ...	★★★★★ 1 Bewertung		95	■	ab € 58,90 (€ 58,900/TB)
	<a href="#">TeamGroup CX2 SSD 2TB, SATA (T253X6002T0C101)</a> Bauform: Solid State Drive (SSD) • Formfaktor: 2.5" • Schnittstelle: SATA 6Gb/s • Lesen: 540MB/s • Schreiben: 490MB/s SLC-Cached • Speichermodule: 3D-NAND TLC, Toshiba/WD, 64 Layer (BICS3) • TBW: 1.6PB • Zuverlässigkeitsprognose: 1 Mio. Stunden ...	(zu wenige)	1 Testbericht	24	■	ab € 119,70 (€ 59,850/TB)
	<a href="#">Intenso Top Performance SSD 1TB, M.2 (3832460)</a> Bauform: Solid State Module (SSM) • Formfaktor: M.2 2280 • Schnittstelle: M.2/B-M-Key (SATA 6Gb/s) • Lesen: 520MB/s • Schreiben: 500MB/s • Protokoll: AHCI • Leistungsaufnahme: keine Angabe (maximal), keine Angabe (Betrieb), keine Angabe ...	★★★★★ 2 Bewertungen		57	■	ab € 59,90 (€ 59,900/TB)



Bild	1468 Produkte	Bewertung (Anzahl)	Testberichte	Angebote	LZ	Preis*  (pro TB)
	<p><a href="#">Toshiba Enterprise Capacity MG08ACA 16TB, 512e, SATA 6Gb/s (MG08ACA16TE)</a></p> <p>Formfaktor: 3.5", 26.1mm • Drehzahl: 7200rpm • Cache: 512MB • Leistungsaufnahme: 7.63W (Betrieb), 4W (Leerlauf) • Lautstärke: keine Angabe (Betrieb), 20dB(A) (Leerlauf) • Aufnahmeverfahren: Conventional Magnetic Recording (CMR), Two Dimensional ...</p>	<p>★★★★★</p> <p>45 Bewertungen</p>	<p><b>80</b></p> <p>aus 1 Test</p>	90		ab € 259,79 (€ 16,237/TB)
	<p><a href="#">Toshiba Enterprise Capacity MG09ACA 18TB, 512e, SATA 6Gb/s (MG09ACA18TE)</a></p> <p>Formfaktor: 3.5", 26.1mm • Drehzahl: 7200rpm • Cache: 512MB • Leistungsaufnahme: 8.35W (Betrieb), 4.16W (Leerlauf) • Lautstärke: keine Angabe (Betrieb), 20dB(A) (Leerlauf) • Aufnahmeverfahren: Flux Control Microwave Assisted Conventional Magnetic ...</p>	<p>★★★★★</p> <p>34 Bewertungen</p>	<p>2</p> <p>Testberichte</p>	81		ab € 295,89 (€ 16,438/TB)
	<p><a href="#">Toshiba Enterprise Capacity MG09ACA 18TB, 4Kn, SATA 6Gb/s (MG09ACA18TA)</a></p> <p>Formfaktor: 3.5", 26.1mm • Drehzahl: 7200rpm • Cache: 512MB • Leistungsaufnahme: 8.35W (Betrieb), 4.16W (Leerlauf) • Lautstärke: keine Angabe (Betrieb), 20dB(A) (Leerlauf) • Aufnahmeverfahren: Flux Control Microwave Assisted Conventional Magnetic ...</p>	<p>(zu wenige)</p>	<p>2</p> <p>Testberichte</p>	2		ab € 296,79 (€ 16,488/TB)
	<p><a href="#">Seagate Exos X - X18 18TB, 512e/4Kn, SATA 6Gb/s (ST18000NM0001)</a></p> <p>Formfaktor: 3.5" • Drehzahl: 7200rpm • Cache: 256MB • Leistungsaufnahme: 6.4W (Betrieb), 5.3W (Leerlauf) • Lautstärke: keine Angabe (Betrieb), keine Angabe (Leerlauf) • Aufnahmeverfahren: Conventional Magnetic Recording (CMR) • Sektoren: 4KB mit ...</p>	<p>★★★★★</p> <p>25 Bewertungen</p>	<p>1</p> <p>Testbericht</p>	114		ab € 299,98 (€ 16,666/TB)
	<p><a href="#">Toshiba Enterprise Capacity MG07ACA 14TB, 512e, SATA 6Gb/s (MG07ACA14TE)</a></p> <p>Formfaktor: 3.5", 26.1mm • Drehzahl: 7200rpm • Cache: 256MB • Leistungsaufnahme: 7.8W (Betrieb), 4.22W (Leerlauf) • Lautstärke: keine Angabe (Betrieb), 20dB(A) (Leerlauf) • Aufnahmeverfahren: Conventional Magnetic Recording (CMR) • Sektoren: 4KB ...</p>	<p>★★★★★</p> <p>19 Bewertungen</p>	<p>2</p> <p>Testberichte</p>	103		ab € 244,29 (€ 17,449/TB)
	<p><a href="#">Seagate SkyHawk +Rescue 4TB, SATA 6Gb/s (ST4000VX007)</a></p> <p>Formfaktor: 3.5" • Drehzahl: 5900rpm • Cache: 64MB • Leistungsaufnahme: 5.5W (Betrieb), 3.2W (Leerlauf) • Lautstärke: 34dB(A) (Betrieb), 30dB(A) (Leerlauf) • Aufnahmeverfahren: Conventional Magnetic Recording (CMR) • Sektoren: 4KB mit Emulation ...</p>	<p>★★★★★</p> <p>18 Bewertungen</p>		106		ab € 69,86 (€ 17,465/TB)
	<p><a href="#">Seagate Exos X - X16 16TB, 512e/4Kn, SATA 6Gb/s (ST16000NM001G)</a></p> <p>Formfaktor: 3.5" • Drehzahl: 7200rpm • Cache: 256MB • Leistungsaufnahme: 6.3W (Betrieb), 5.0W (Leerlauf) • Lautstärke: keine Angabe (Betrieb), keine Angabe (Leerlauf) • Aufnahmeverfahren: Conventional Magnetic Recording (CMR) • Sektoren: 4KB mit ...</p>	<p>★★★★★</p> <p>21 Bewertungen</p>	<p><b>80</b></p> <p>aus 1 Test</p>	118		ab € 284,94 (€ 17,809/TB)
	<p><a href="#">Seagate Exos X - X16 14TB, 512e/4Kn, SATA 6Gb/s (ST14000NM001G)</a></p> <p>Formfaktor: 3.5" • Drehzahl: 7200rpm • Cache: 256MB • Leistungsaufnahme: 6.3W (Betrieb), 5.0W (Leerlauf) • Lautstärke: keine Angabe (Betrieb), keine Angabe (Leerlauf) • Aufnahmeverfahren: Conventional Magnetic Recording (CMR) • Sektoren: 4KB mit ...</p>	<p>★★★★★</p> <p>9 Bewertungen</p>	<p><b>80</b></p> <p>aus 1 Test</p>	93		ab € 249,48 (€ 17,820/TB)



- ⚙️ **persistent** storage, although physical corruption happens all the time
- 🔗 easy/fast (byte-addressable) **random** accesses, although built for sequential accesses (in blocks)
- ∞ almost **endless** capacity (for files, for data within a file), despite very real limitations
- 🕒 **fast**, but actually slow
- 📁 **names** for files and directories, but actually just bits and bytes



What to do when performance is bad? Caches!

-  DRAM cache inside modern storage devices
-  Page cache in software, in the OS

- Files buffered page-wise in “page cache”
- Lower access time for frequently accessed data
- Use up all the memory
  - Pages are freed on demand
- Deduplicate pages (copy-on-write)

```
00000000: 25 50 44 46 2D 31 2E 35|0A 25 B5 ED AE FB 0A 31 %PDF-1.5%. ....1
00000010: 32 20 30 20 6F 62 6A 0A|3C 3C 20 2F 4C 65 6E 67 2 0 obj.<< /Leng
00000020: 74 68 20 31 33 20 30 20|52 0A 20 20 20 2F 46 69 th 13 0 R. /Fi
00000030: 6C 74 65 72 20 2F 46 6C|61 74 65 44 65 63 6F 64 lter /FlateDecod
00000040: 65 0A 3E 3E 0A 73 74 72|65 61 6D 0A 78 9C ED 5D e.>>.stream.x..]
00000050: 6D 8F 1C B7 91 FE BE BF|82 30 2E C0 2C A0 ED E5 m.....0.,...
00000060: 3B D9 BE 20 86 63 FB 9C|1C 6C 24 B6 94 04 38 6D ;.. .c...l$....8m
00000070: 10 8C 76 7B 76 27 1A CD|AC 66 66 25 CB BF FE 9E ..v{v'...ff%....
00000080: 62 BF 4C 77 4F 93 D3 BD|A3 03 0E 97 93 EC D5 BC b.Lw0.....
00000090: B0 8A C5 AA 62 D5 53 24|9B 2B 18 C7 DF 2B 81 1F ....b.S$.+...+.
000000A0: 5E 4B 76 FB EE E2 FD C5|4F EC FD 85 B2 0C FF 19 ^Kv.....0.....
000000B0: A9 B2 3C 97 CC 39 CE B6|05 FB 1B 5B 5F 08 46 7F ..<..9.....[_.F00
000000C0: B7 F7 EC 7A CE D9 FD 6E|B8 E1 A2 FA 58 78 97 79 ...z...n....Xx.y
000000D0: AF 98 10 99 54 BA FA 26|E7 99 E0 86 59 9E 49 EE ....T..&....Y.I.
000000E0: 98 96 19 CF 35 E3 99 B2|AE DB C0 49 B0 B4 43 0D ....5.....I..C.
000000F0: 1C 3E F1 4C 48 93 71 2B|D1 B7 C8 3C 17 4C F2 4C .>.LH.q+...<.L.L
00000100: 5B D1 6D A2 6D 66 A5 68|9A 08 95 09 23 3B 4D A4 [.m.mf.h....#;M.
00000110: E0 99 E5 72 B0 89 16 99|06 13 2E 33 0D 1E 3C CF ...r.....3..<.
00000120: B4 73 9D 6E 0C 68 72 83|16 3E D3 CA 33 63 32 6B .s.n.hr..>..3c2k
00000130: 49 B0 CC F9 BC 6C 81 C6|DE 4A 67 D8 F1 0B E8 50 I....l...Jg....P
00000140: F9 CC 41 EB 52 E6 41 3F|46 E0 5F BC 6F 8F F5 D0 ..A.R.A?F._.o...
00000150: 82 A4 2C BF E1 59 2E 74|CD DF 29 FA C3 8E 5F 80 ...Y.t..)...._
00000160: BF 31 2E B3 C2 35 1D 1C|91 D7 EC 15 54 8E A1 0E .1...5.....T...
00000170: 00 00 00 00 00 00 00 00|00 00 00 00 00 00 00 00 MM: \ /C
```

```

00000000: 46 6C 61 74 20 70 72 6F|66 69 6C 65 3A 0A 0A 45   Flat profile:..E
00000010: 61 63 68 20 73 61 6D 70|6C 65 20 63 6F 75 6E 74   ach sample count
00000020: 73 20 61 73 20 30 2E 30|31 20 73 65 63 6F 6E 64   s as 0.01 second
00000030: 73 2E 0A 20 20 25 20 20|20 63 75 6D 75 6C 61 74   s.. % cumulati
00000040: 69 76 65 20 20 20 73 65|6C 66 20 20 20 20 20 20   ve self
00000050: 20 20 20 20 20 20 20 20|73 65 6C 66 20 20 20 20   self
00000060: 20 74 6F 74 61 6C 20 20|20 20 20 20 20 20 20 20   total
00000070: 20 0A 20 74 69 6D 65 20|20 20 73 65 63 6F 6E 64   . time second
00000080: 73 20 20 20 73 65 63 6F|6E 64 73 20 20 20 20 63   s seconds c
00000090: 61 6C 6C 73 20 20 6D 73|2F 63 61 6C 6C 20 20 6D   alls ms/call m
000000A0: 73 2F 63 61 6C 6C 20 20|6E 61 6D 65 20 20 20 20   s/call name
000000B0: 0A 20 36 30 2E 30 30 20|20 20 20 20 20 30 2E 30   . 60.00 0.0
000000C0: 33 20 20 20 20 20 30 2E|30 33 20 31 36 37 37 37   3 0.03 16777
000000D0: 32 31 36 20 20 20 20 20|30 2E 30 30 20 20 20 20   216 0.00
000000E0: 20 30 2E 30 30 20 20 66|61 73 74 0A 20 32 30 2E   0.00 fast. 20.
000000F0: 30 30 20 20 20 20 20 20|30 2E 30 34 20 20 20 20   00 0.04
00000100: 20 30 2E 30 31 20 20 20|20 20 20 20 20 31 20 20   0.01 1
00000110: 20 20 31 30 2E 30 30 20|20 20 20 34 30 2E 30 30   10.00 40.00
00000120: 20 20 73 6C 6F 77 0A 20|32 30 2E 30 30 20 20 20   slow. 20.00
00000130: 20 20 20 30 2E 30 35 20|20 20 20 20 30 2E 30 31   0.05 0.01
00000140: 20 20 20 20 20 20 20 20|20 20 20 20 20 20 20 20
00000150: 20 20 20 20 20 20 20 20|20 20 20 20 20 5F 69 6E   _in
00000160: 69 74 0A 0A 20 25 20 20|20 20 20 20 20 20 74   it % t

```

dgruss@hpx360dg / % mount

sysfs on /sys type sysfs (rw,nosuid,nodev,noexec,relatime)

proc on /proc type proc (rw,nosuid,nodev,noexec,relatime)

udev on /dev type devtmpfs (rw,nosuid,relatime,size=7954268k,nr\_inodes=1988567,mode=755,inode64)

devpts on /dev/pts type devpts (rw,nosuid,noexec,relatime,gid=5,mode=620,ptmxmode=000)

tmpfs on /run type tmpfs (rw,nosuid,nodev,noexec,relatime,size=1602616k,mode=755,inode64)

/dev/mapper/ubuntu--vg-root on / type ext4 (rw,noatime,errors=remount-ro)

securityfs on /sys/kernel/security type securityfs (rw,nosuid,nodev,noexec,relatime)

tmpfs on /dev/shm type tmpfs (rw,nosuid,nodev,inode64)

tmpfs on /run/lock type tmpfs (rw,nosuid,nodev,noexec,relatime,size=5120k,inode64)

cgroup2 on /sys/fs/cgroup type cgroup2 (rw,nosuid,nodev,noexec,relatime,nsdelegate,memory\_recursiveprot)

pstore on /sys/fs/pstore type pstore (rw,nosuid,nodev,noexec,relatime)

efivarfs on /sys/firmware/efi/efivars type efivarfs (rw,nosuid,nodev,noexec,relatime)

bpf on /sys/fs/bpf type bpf (rw,nosuid,nodev,noexec,relatime,mode=700)

systemd-1 on /proc/sys/fs/binfmt\_misc type autofs (rw,relatime,fd=30,pgrp=1,timeout=0,minproto=5,maxproto=5)

mqueue on /dev/mqueue type mqueue (rw,nosuid,nodev,noexec,relatime)

hugetlbfs on /dev/hugepages type hugetlbfs (rw,relatime,pagesize=2M)

debugfs on /sys/kernel/debug type debugfs (rw,nosuid,nodev,noexec,relatime)

tracefs on /sys/kernel/tracing type tracefs (rw,nosuid,nodev,noexec,relatime)

fusectl on /sys/fs/fuse/connections type fusectl (rw,nosuid,nodev,noexec,relatime)

configfs on /sys/kernel/config type configfs (rw,nosuid,nodev,noexec,relatime)

none on /run/credentials/systemd-sysusers.service type ramfs (ro,nosuid,nodev,noexec,relatime,mode=700)

tmpfs on /run/qemu type tmpfs (rw,nosuid,nodev,relatime,mode=755,inode64)



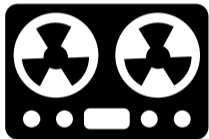

- 📍 tape drives, disks, ...
  - 📄 sequential access
  - 📄 one byte after the other
  - ↔️ `seek()` other positions to access other parts
  - 🕒 random access possible, but slow



Optimize for small files or large files?

- number of them?
- space they occupy?
- ⋯ accesses to them?
- ↔ sequential vs. random access?
- ↗ size changes over time?



## ■ Small files:

- Small blocks → low internal fragmentation
- Fast concurrent operations
- Files used together should be stored together (why?)

## ■ Large files:

- Large blocks → low external fragmentation
- Contiguous allocation for fast sequential access
- Efficient lookup within the file for random access



## Directory

- Group of named files or subdirectories → store in a metadata block
- Mapping from file name to file Metadata location

## Path

- String that uniquely identifies file or directory
- `/var/www/teaching/courses/os`



## Links

- Hard link: name to metadata
- Soft link: name to name

## Mount





- Link name in one file system to root of another



- ⌨ creating and deleting files: `create()`, `unlink()`
- 🔗 linking files (creating a hard link) `link()`
- 📁 directory operations: `mkdir()`, `rmdir()`
- 📄 open to start accessing a file: `open()` (actually much more than just that)
- 📄 close to end accessing the file: `close()`



kind of like the tape drive model...?

-  reading from a file: `read()`
-  writing to a file: `write()`
-  positioning `seek()`
-  force modification to storage: `fsync()`



■ split storage into blocks

- what is a good block size?
- file name → meta data + blocks

🔍 how to find data blocks? → **file index**

🔍 where are free data blocks on the storage? how to allocate them?

📍 Locality: blocks/files/folders?

💧 Reliability: crash during file system operation?







- old! (1970s)
- file system for MS-DOS and early Windows
- many enhancements
- Today: exFAT for SD-cards, USB sticks, ...



- Blocks? Sectors! Which size? 512 bytes
- Sectors are too small... 4096
- ≡ Files: cluster of  $2^n$  sectors ( $n = 0 \dots 6$ ) – contiguous sectors!!
- 🔗 FAT: cluster status + pointer to next one (if file is larger than one cluster)
  - Cluster number → works exactly like physical page number!
- 📁 Directory: file name, starting cluster, length



- FAT12: 12bit FAT entry  $\rightarrow 2^{12}$  clusters (512B-4KB)  $\rightarrow$  max. 16 MB
- FAT16: 16bit FAT entry  $\rightarrow 2^{16}$  (2KB-32KB)  $\rightarrow$  max. 2 GB
- FAT32: 28bit FAT entry  $\rightarrow 2^{28}$  (4KB-32KB)  $\rightarrow$  max. 2 TB (limited by a 32-bit sector count field)

Entry	Pointer		Entry	Pointer
2	0		71	72
3	0		72	0xffff
4	0		73	74
:	:	2nd cluster chain starts at cluster 73 (length 5)	74	75
40	0		75	76
41	0		76	77
42	43		77	0xffff
43	44		78	0
44	45		79	0
::	::		80	0
70	71		:	0

1st cluster chain starts at cluster 42 (length 31)

**Boot Sector**

- FAT type
- FAT size
- Root Directory size

**Root Directory**

tyui.jpg

- start cluster = 2
- length = 1400B

mes.doc

- start cluster = 5
- length = 980B

**FATs**

2: 3

3: 4

4: 0xFF

5: 6

6: 0xFF

7: 0x00

8: 0x00

9: 0x00

Sector 0

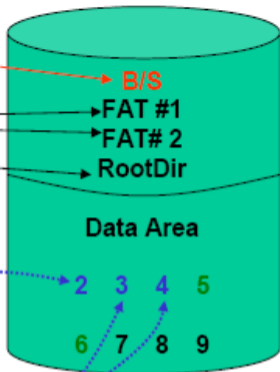

Reserved  
Area



- FAT area for table
- Data area for the data of files, in clusters

## Root Directory

File Name	Size	Cluster
gary.txt	1034	6
hello.jpg	3973	3

*Cluster*



## File Allocation Table

Cluster	Next
2	0
3	8
4	0
5	0
6	0xFF
7	0
8	0xFF
9	0

*Cluster = 2048 B = 4 sectors*



---

Bytes	Purpose
0-2	Assembly code instructions to jump to boot code (mandatory in bootable partition)
3-10	OEM name in ASCII
11-12	Bytes per sector (512, 1024, 2048, or 4096)
13	Sectors per cluster (Must be a power of 2 and cluster size must be $i=32$ KB)
14-15	Size of reserved area, in sectors
16	Number of FATs (usually 2)
17-18	Maximum number of files in the root directory (FAT12/16; 0 for FAT32)
19-20	Number of sectors in the file system; if 2 B is not large enough, set to 0 and use 4 B value in bytes 32-35 below
21	Media type (0xf0=removable disk, 0xf8=fixed disk)
22-23	Size of each FAT, in sectors, for FAT12/16; 0 for FAT32
24-25	Sectors per track in storage device
26-27	Number of heads in storage device
28-31	Number of sectors before the start partition
32-35	Number of sectors in the file system; this field will be 0 if the 2B field above (bytes 19-20) is non-zero

---

# FAT Boot Sector (FAT12/FAT16)



Bytes	Purpose
0-35	(See previous table)
36	BIOS INT 13h (low level disk services) drive number
37	Not used
38	Extended boot signature to validate next three fields (0x29)
39-42	Volume serial number
43-53	Volume label, in ASCII
54-61	File system type level, in ASCII. (Generally "FAT", "FAT12", or "FAT16")
62-509	Not used
510-511	Signature value (0xaa55)

Sector(s)	Address	Function
0	0x0000-0x01ff	Boot Sector
1-9	0x0200-0x13ff	File Allocation Table (primary)
10-18	0x1400-0x25ff	File Allocation Table (secondary)
19-32	0x2600-0x41ff	Root Directory (this is the maximum size!)
33-2879	0x4200-0x167fff	File storage space

- after FAT(s) - or in FAT32: specified in boot sector
- new file entry needed? first / next-available search

Root Directory SFN Entry Data Structure	
Bytes	Purpose
0	First character of file name (ASCII) or allocation status (0x00=unallocated, 0xe5=deleted)
1-10	Characters 2-11 of the file name (ASCII); the "." is implied between bytes 7 and 8
11	File attributes (see File Attributes table)
12	Reserved
13	File creation time (in tenths of seconds)*
14-15	Creation time (hours, minutes, seconds)*
16-17	Creation date*
18-19	Access date*
20-21	High-order 2 bytes of address of first cluster (0 for FAT12/16)*
22-23	Modified time (hours, minutes, seconds)
24-25	Modified date
26-27	Low-order 2 bytes of address of first cluster
28-31	File size (0 for directories)

File Attributes	
Flag Value	Description
0000 0001 (0x01)	Read-only
0000 0010 (0x02)	Hidden file
0000 0100 (0x04)	System file
0000 1000 (0x08)	Volume label
0000 1111 (0x0f)	Long file name
0001 0000 (0x10)	Directory
0010 0000 (0x20)	Archive

\* Bytes 13-22 are unused by DOS

- Root directory (32 bytes each):
- also possible: extra 32 bytes for "long" filename

1. Find free entry in directory
2. Find free entry in FAT for cluster, write sector number there and EOF into FAT
3. write start sector into directory

Extending files? if next FAT entry is free, move EOF to that instead



- widely used - simple, wide supporting
- principle of locality?
  - fragmented files
  - iterate through directories and FAT frequently
- Limited metadata and access control
- No hard links
- limitation of volume and file size
- reliability techniques??



- Unix Fast File System - released mid 1980
- many data-structures identical to Ritchie/Thomposon's original UNIX FS (1970ies)
- Tree-based multi-level index

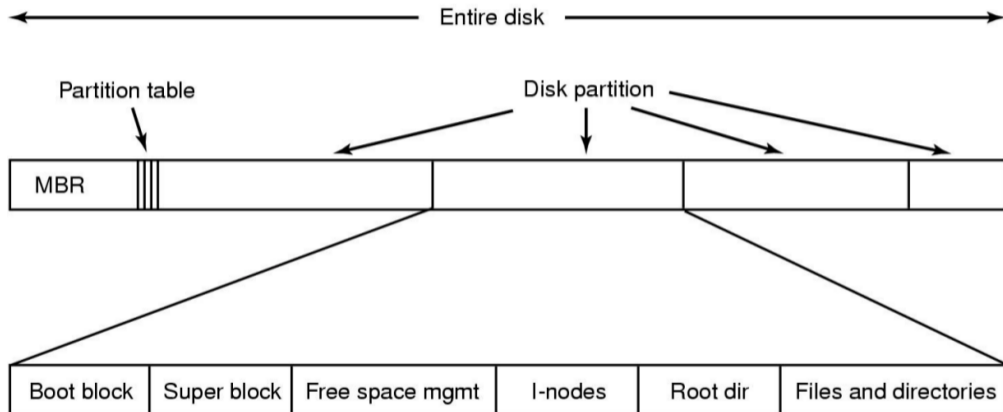

**Figure 1:** Disk layout, classical example





- boot block: Boot Loader, to boot system
- super block: Infos on file system, e.g.
  - size of partition, block size, free block list, ...
  - ...
- index nodes (inodes)
  - inodes  $\leftrightarrow$  files
- data blocks

# Inode Array

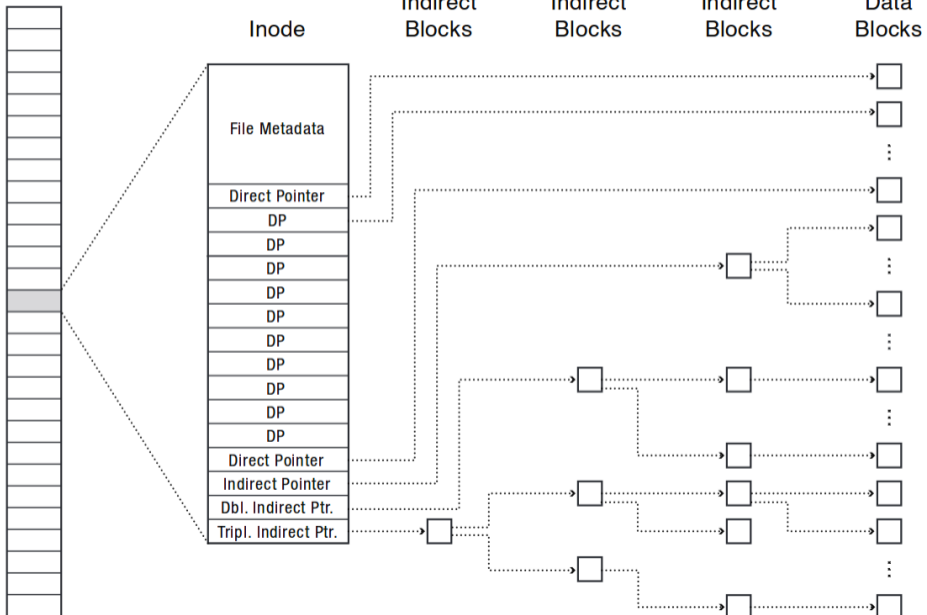

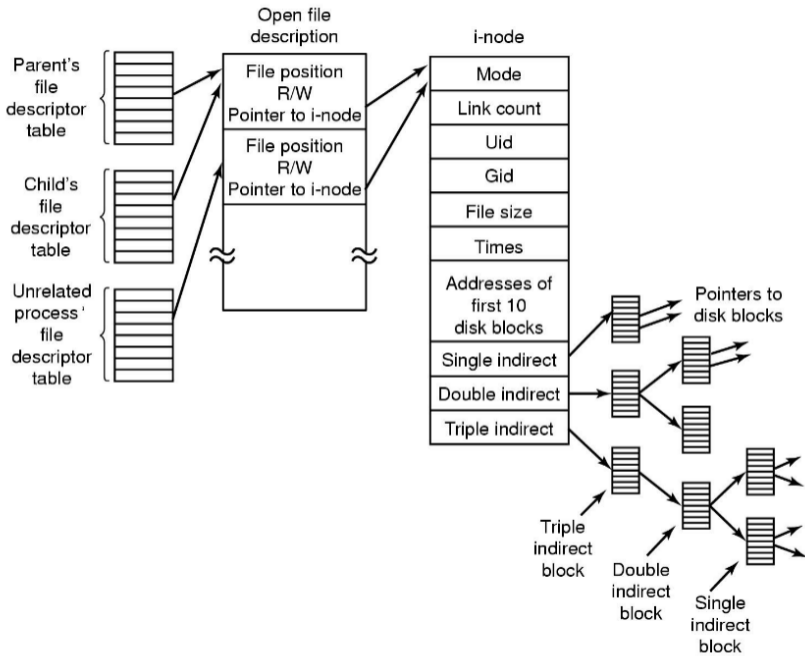

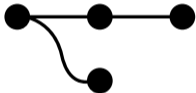

- Attributes:
  - type: file, directory, character special file, block special file
  - owner: user, group
  - created, modified, accessed times
  - size: in bytes and blocks
  - permissions (rwx)
  - NO filename

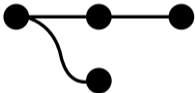

- files may have multiple names
  - directories contain names and numberings
  - multiple occurrences possible
  - “hard link”
  - inode contains link count

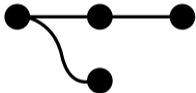

- Inode link-count 0:
  - no more reference within file system exists
  - file can be deleted
- number of inodes limited
  - file system may be full, because
    - no free inode
    - all blocks used

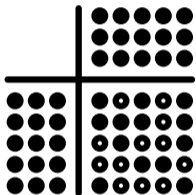

- Sparse file: one or more empty spaces are surrounded by file data
- empty space: needs not consume disk spaces

```
fd=creat("test.file",777);  
lseek(fd,1000000000,SEEK_SET);  
write(fd,"test",2);  
close(fd);
```

- Should create a file of size ~1GB using one block
  - does the file system support it?

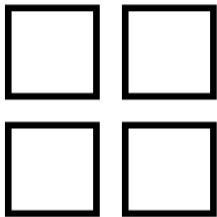

- places data to optimize concurrent access to
  - data blocks of a file
  - metadata of a file
  - different files from the same directory
- different directories may be far from each others





- Microsoft **N**ew **T**echnology **F**ile **S**ystem
- released 1993
- many new features compared to FAT
  - new index structures
  - flexible metadata
  - improved security
  - improved reliability
- still the primary file system for Windows



- **Extents:** variable sized region of a file stored in a contiguous region on the storage device
- **Flexible Tree and Master File Table(MFT):** each file represented by a tree
  - small number of extents: shallow tree
  - badly fragmented file: deeper tree
- **Root:** stored in a MFT (similar to inode array)
  - array of 1KB MFT records
  - contains sequence of variable-size attribute records
    - can contain data and metadata
    - data is an attribute of a file-system

MFT

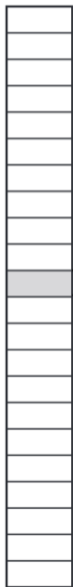

MFT Record

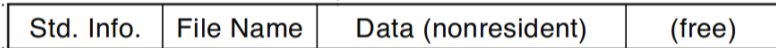

Start

Length

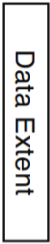

Data Extent

Start

Length

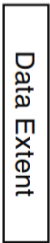

Data Extent



- MFT contains *nonresident data* attribute
  - sequence of extent pointers
  - specify starting block and length of blocks of an extent
  - extent: variable size - can be multiple GBs
- File small? attribute may even contain data

MFT



MFT Record (small file)

Std. Info.	File Name	Data (resident)	(free)
------------	-----------	-----------------	--------

MFT

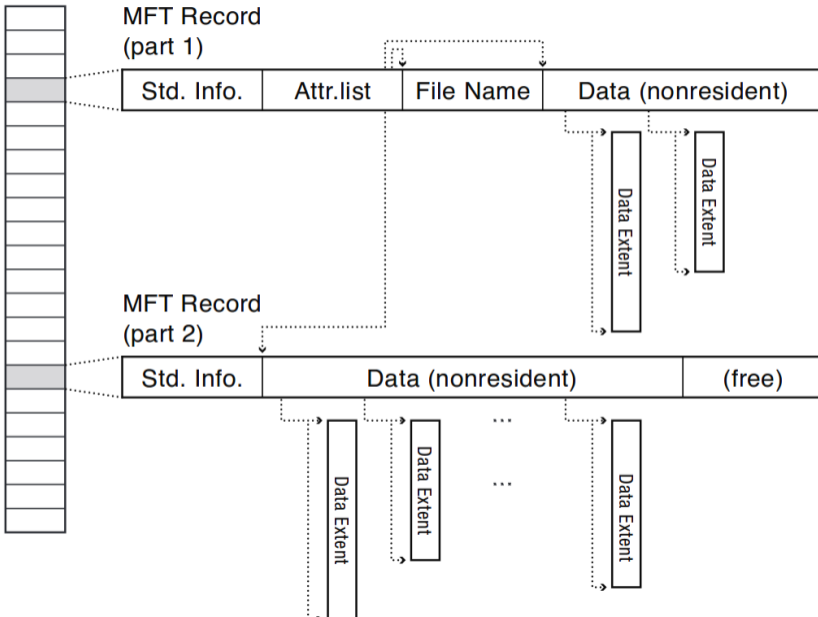

MFT

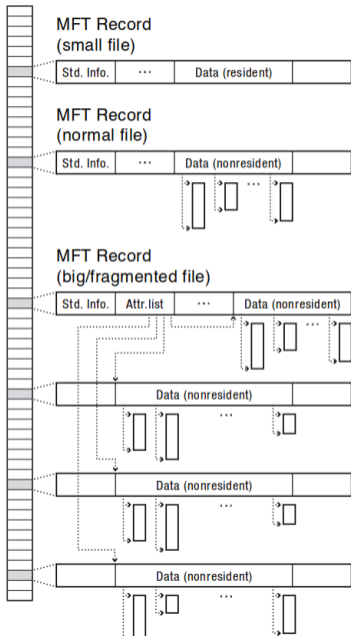

MFT

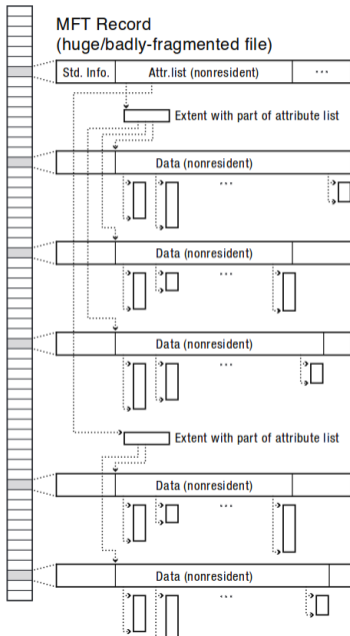



- no special regions for file system metadata
- all metadata in ordinary files:
  - file 5: root directory
  - file 6: free space bitmap
  - file 8: bad block list
  - file 9: security and access control information
  - file 0: master file table of contents
    - first sector contains a pointer to first MFT entry
- makes it easier to dynamically grow metadata



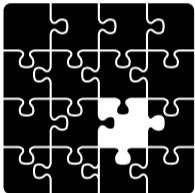

- variation of “best fit” - place a newly allocated file in the smallest free region large enough
- applications can indicate expected file size
- start of volume reserved for MFT table to avoid fragmentation





- COW file systems never overwrite existing data or metadata
  - write new versions to new locations
  - Example - append a block to a file

# Why would we need COW file systems?



- small writes are expensive
  - Caches filter reads
  - Flash Storage / SSDs?
- move data to new pages
- Versioning



- linux-based file systems
- originally “cross-development” in Minix
- based on the Minix file system
- VFS: virtual file system layer

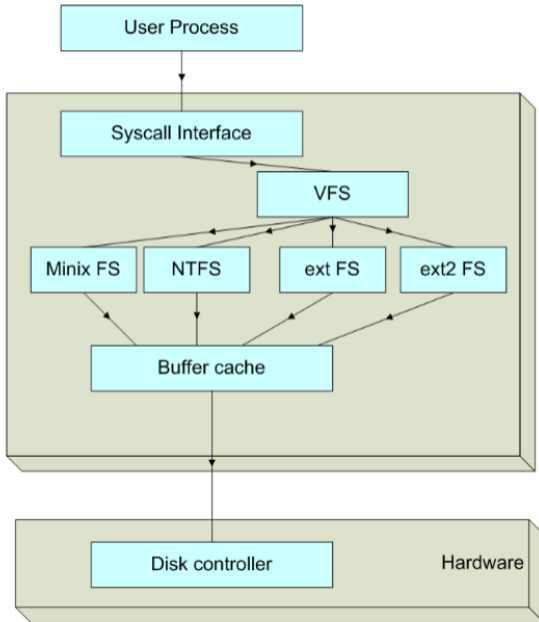



**HOW MANY MORE FILE SYSTEMS DO  
YOU WANT TO LOOK AT!?!?!?!?**



- ext: extended file system (1992)
  - supported VFS
  - 2 GB disk size
  - 255 Byte file names





- designed for extensibility
- used until Kernel 2.6.17 volume size limited to 2TB
- also uses cylinder groups, superblocks, inodes, ...



- c: compressed
- s: secured
- S: synchronized
- A: append mode



### symbolic links

- symlink: special file that contains name of another file
- stored in file data blocks, or

→ inode contains actual file name

clean/dirty state (→ kind of a simple journal)

- after OS crash: fsck recommended/enforced

→ regular file system checks (fsck), even if clean



- inodes and data blocks “close” to each other on hard disk
- on magnetic disks: reduces seek times

Preallocation:

- allocating a block to a file results in allocating up to 8 continuous blocks
- improves write- and read performance

Bitmaps for

- inode allocation
- data allocation

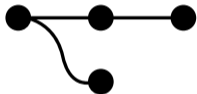

maximum file size

- depends on block size  $b$
- $\min\left(\left(\frac{b}{4}\right)^3 + \left(\frac{b}{4}\right)^2 + \frac{b}{4} + 12\right) * b, 2^{32} * b$ 
  - $b=1\text{KB}$ : 16GB
  - $b=4\text{KB}$ : 2 TB



- based on ext2
- **journaling** file system
- file systems can grow dynamically
- hash tree for big directories



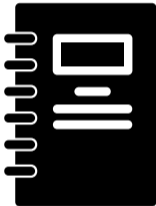

- changes to files stored in a journal
  - in principle a cyclic log
- first change noted in journal
- then executed in file system
- after crash: allows fixing inconsistencies easier



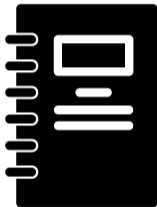

- file system is consistent
- changes are requested
- changes noted in journal
- changes executed in file system
- similar to stable storage concept



deleting a file may need two steps:

1. remove reference from directory
2. delete inode

Crash between the two steps?

- orphaned inode
- inconsistency

Change their order?

- directory references non-existing inode

→ using that inode may have fatal consequences



- Without Journal: fsck - file system check at reboot and **hope to find those inconsistencies**
- Now:
  - Read entries from journal
  - execute changes if required
- much faster than fsck
- changes become atomic:
  - either completed before the crash
  - or executed after the crash based on the journal
  - or not at all if not yet in the journal

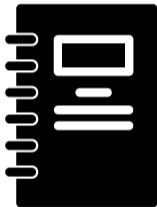

- storage: regular file, hidden file, special disk area, separate device?
- do we need a journal for the journal?
- must be able to check the integrity of the journal
  - checksum
  - ignore entries with incorrect checksum

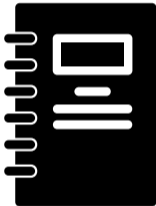

- writes a copy of each block
  - first into the journal
  - then on the disk
- Crash:
  - neither in journal nor on disk: no change
  - only in journal: copy to disk
  - already on disk: nothing to do
- high overhead
- acceptable for high correctness requirements

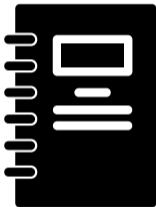

- only meta-data written to journal
  - trades safety against performance
  - may lead to asynchronicity between meta-data and data
- for example, a correctly resized file but garbage content



- full journal (no risk): 1. data  $\rightarrow$  journal; 2. data  $\rightarrow$  disk
- ordered (medium risk): 1. meta-data  $\rightarrow$  journal; 2. data  $\rightarrow$  disk
- write-back (highest risk): 1. meta-data  $\rightarrow$  journal; 2. data “eventually”  $\rightarrow$  disk (`sync`)
- no checksums on journal



- successor of ext3
- volume size up to 1 exibyte ( $2^{60}$ )
- file size up to 16 tebibytes ( $2^{40}$ )
- extents
- preallocation
- journals with checksum





**ITS OVER**

**ITS FINALLY OVER**