

Model checking HW3 - Solution and common mistakes

Step: 1, $k = 1$

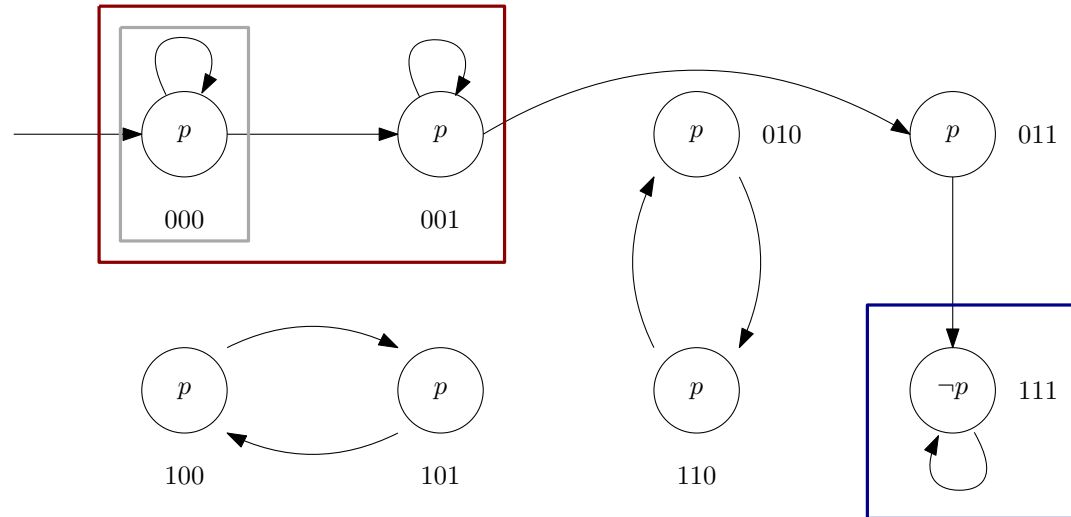

$$Q = \{000\}$$

$$A = Q(s_0) \wedge R(s_0, s_1)$$

$$A = \text{post}(Q) = \{000, 001\}$$

$$B = \bigwedge_{i=1}^{k-1} R(s_i, s_{i+1}) \wedge \bigwedge_{i=1}^k \neg p(s_i)$$

$$B = \{111\}$$

Model checking HW3 - Solution and common mistakes

Step: 1, $k = 1$

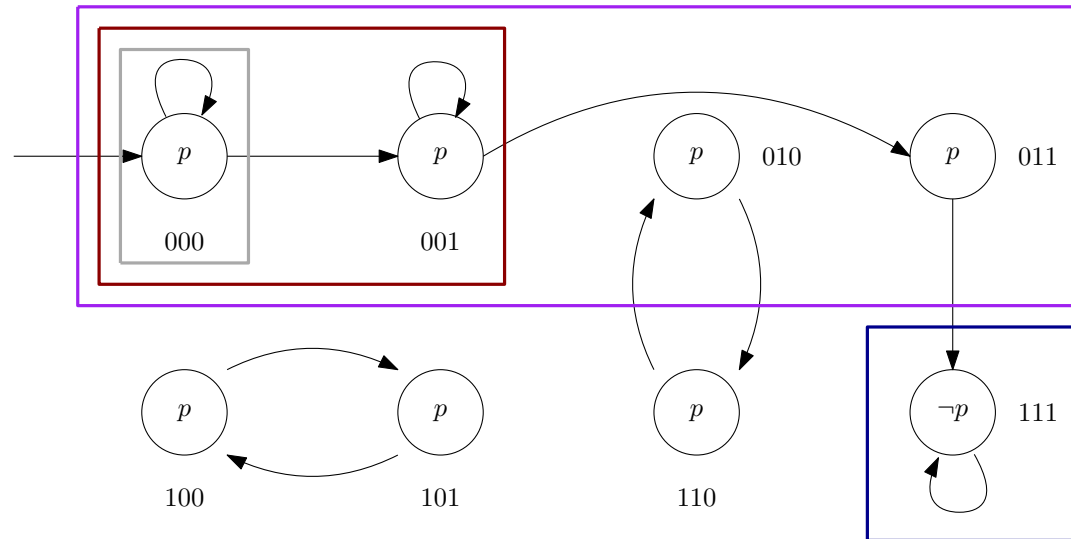

$$Q = \{000\}$$

$$A = Q(s_0) \wedge R(s_0, s_1)$$

$$A = \text{post}(Q) = \{000, 001\}$$

$$B = \bigwedge_{i=1}^{k-1} R(s_i, s_{i+1}) \wedge \bigwedge_{i=1}^k \neg p(s_i)$$

$$B = \{111\}$$

$$\phi = A \wedge B \rightarrow \text{UNSAT}$$

$$I = \text{post}(Q) = \neg x_1 \wedge \neg x_2$$

- Eliminate x_3 ? (already not present)

$$\neg x_1 \wedge \neg x_2 \cap B = \emptyset \rightarrow \checkmark$$

- Eliminate x_2 ?

$$\neg x_1 \cap B = \emptyset \rightarrow \checkmark$$

- Eliminate x_1 ?

$$\top \cap B \neq \emptyset \rightarrow \times$$

$$I = \neg x_1$$

$$I(s_0) \subseteq Q? \rightarrow \times$$

$$\hookrightarrow Q := Q \vee I$$

Model checking HW3 - Solution and common mistakes

Step: 2, $k = 1$

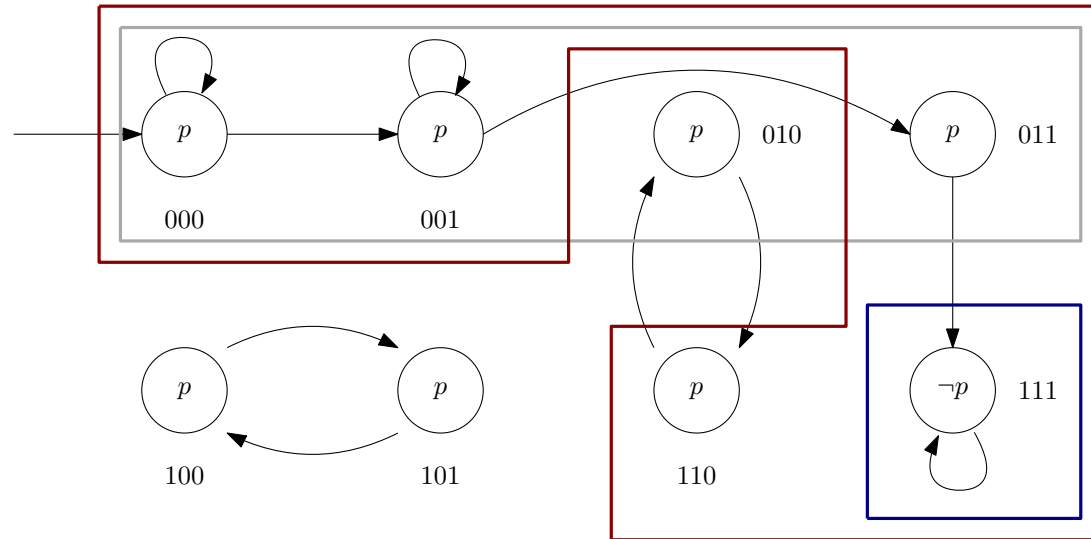

$$Q = \{000, 001, 010, 011\}$$

$$A = Q(s_0) \wedge R(s_0, s_1)$$

$$A = \text{post}(Q) = \{000, 001, 011, 110, 111\}$$

$$B = \bigwedge_{i=1}^{k-1} R(s_i, s_{i+1}) \wedge \bigwedge_{i=1}^k \neg p(s_i)$$

$$B = \{111\}$$

Model checking HW3 - Solution and common mistakes

Step: 2, $k = 1$

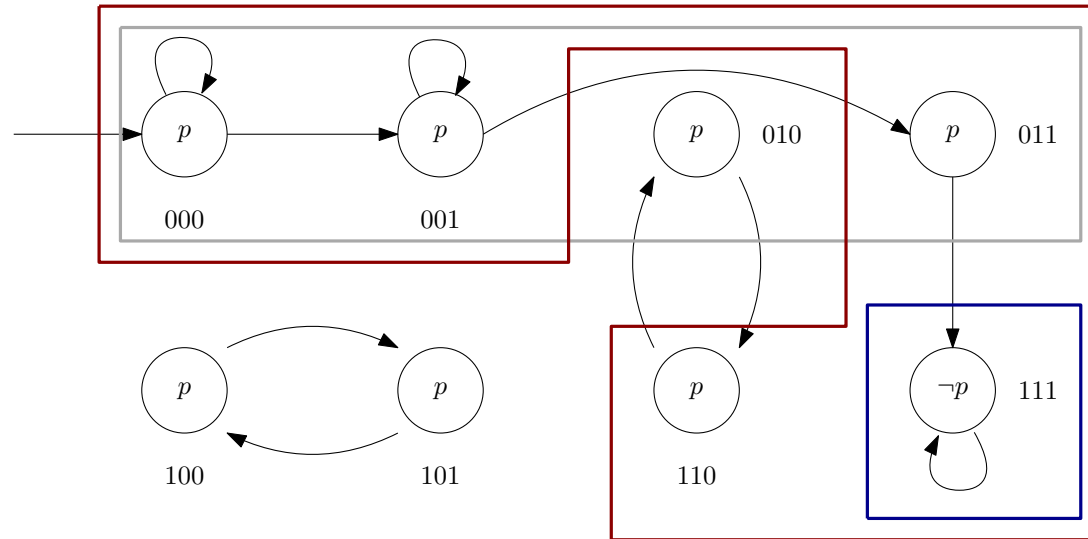

$$Q = \{000, 001, 010, 011\}$$

$$A = Q(s_0) \wedge R(s_0, s_1)$$

$$A = \text{post}(Q) = \{000, 001, 011, 110, 111\}$$

$$B = \bigwedge_{i=1}^{k-1} R(s_i, s_{i+1}) \wedge \bigwedge_{i=1}^k \neg p(s_i)$$

$$B = \{111\}$$

$$\phi = A \wedge B \rightarrow \text{SAT}$$

$$\begin{array}{l} \downarrow \\ Q = S_0? \rightarrow \mathbf{x} \\ \rightarrow k := k + 1 \end{array}$$

Model checking HW3 - Solution and common mistakes

Step: 3, $k = 2$

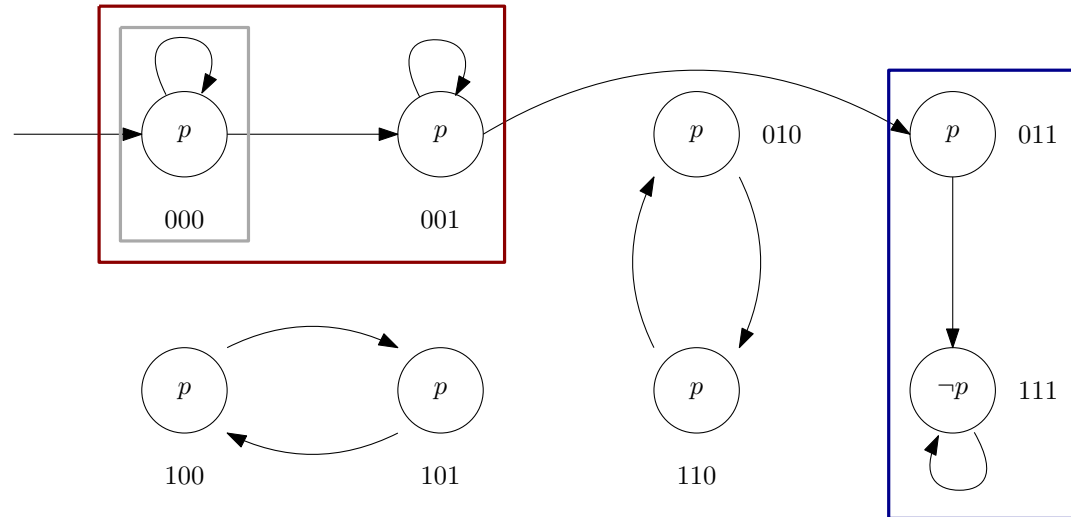

$$Q = \{000\}$$

$$A = Q(s_0) \wedge R(s_0, s_1)$$

$$A = \text{post}(Q) = \{000, 001\}$$

$$B = \bigwedge_{i=1}^{k-1} R(s_i, s_{i+1}) \wedge \bigwedge_{i=1}^k \neg p(s_i)$$

$$B = \{011, 111\}$$

Model checking HW3 - Solution and common mistakes

Step: 3, $k = 2$

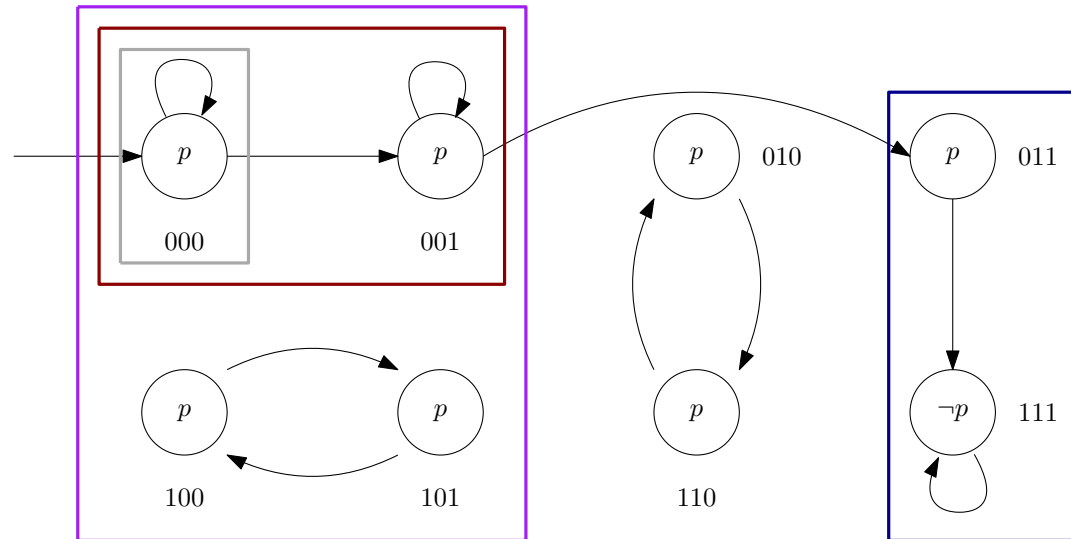

$$Q = \{000\}$$

$$A = Q(s_0) \wedge R(s_0, s_1)$$

$$A = \text{post}(Q) = \{000, 001\}$$

$$B = \bigwedge_{i=1}^{k-1} R(s_i, s_{i+1}) \wedge \bigwedge_{i=1}^k \neg p(s_i)$$

$$B = \{011, 111\}$$

$$\phi = A \wedge B \rightarrow \text{UNSAT}$$

$$I = \text{post}(Q) = \neg x_1 \wedge \neg x_2$$

- Eliminate x_3 ? (already not present)

$$\neg x_1 \wedge \neg x_2 \cap B = \emptyset \rightarrow \checkmark$$

- Eliminate x_2 ?

$$\neg x_1 \cap B \neq \emptyset \rightarrow \times$$

- Eliminate x_1 ?

$$\neg x_2 \cap B = \emptyset \rightarrow \checkmark$$

$$I = \neg x_2$$

$$I(s_0) \subseteq Q? \rightarrow \times$$

$$\hookrightarrow Q := Q \vee I$$

Model checking HW3 - Solution and common mistakes

Step: 3, $k = 2$

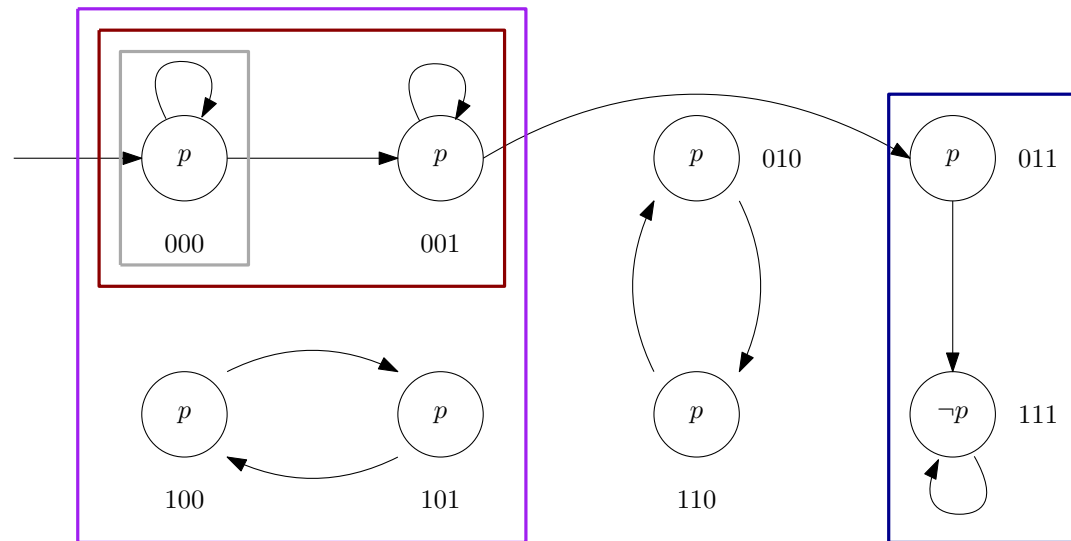

Note: Some students stop here, don't check whether x_1 can be eliminated or not. In that case, the interpolant you get is $I = \neg x_1 \wedge \neg x_2$. This is also an interpolant, albeit smaller than it could have been.

$$Q = \{000\}$$

$$A = Q(s_0) \wedge R(s_0, s_1)$$

$$A = \text{post}(Q) = \{000, 001\}$$

$$B = \bigwedge_{i=1}^{k-1} R(s_i, s_{i+1}) \wedge \bigwedge_{i=1}^k \neg p(s_i)$$

$$B = \{011, 111\}$$

$$\phi = A \wedge B \rightarrow \text{UNSAT}$$

$$I = \text{post}(Q) = \neg x_1 \wedge \neg x_2$$

- Eliminate x_3 ? (already not present)

$$\neg x_1 \wedge \neg x_2 \cap B = \emptyset \rightarrow \checkmark$$

- Eliminate x_2 ?

$$\neg x_1 \cap B \neq \emptyset \rightarrow \times$$

- Eliminate x_1 ?

$$\neg x_2 \cap B = \emptyset \rightarrow \checkmark$$

$$I = \neg x_2$$

$$I(s_0) \subseteq Q? \rightarrow \times$$

$$Q := Q \vee I$$

Model checking HW3 - Solution and common mistakes

Step: 4, $k = 2$

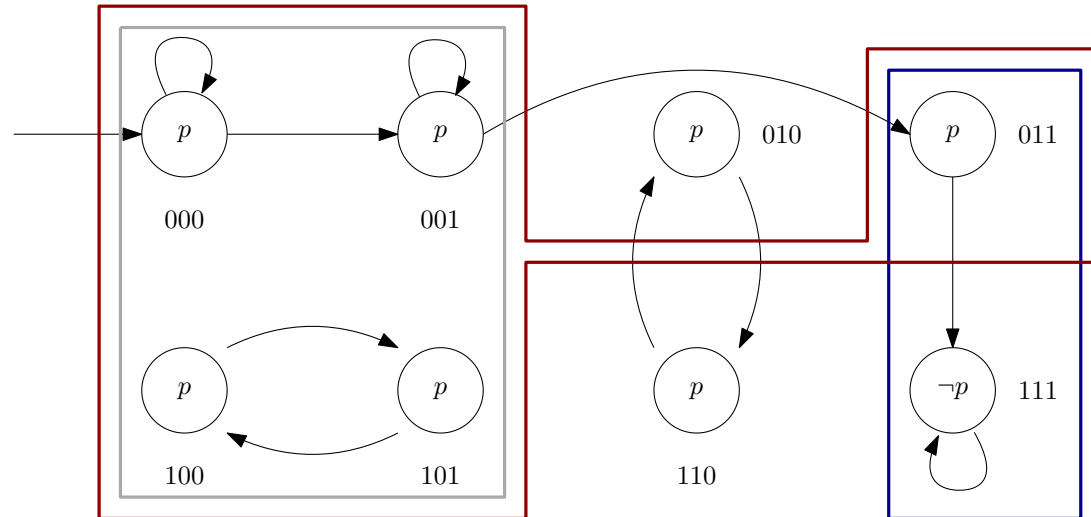

$$Q = \{000, 001, 100, 101\}$$

$$A = Q(s_0) \wedge R(s_0, s_1)$$

$$A = \text{post}(Q) = \{000, 001, 100, 101, 011\}$$

$$B = \bigwedge_{i=1}^{k-1} R(s_i, s_{i+1}) \wedge \bigwedge_{i=1}^k \neg p(s_i)$$

$$B = \{011, 111\}$$

Model checking HW3 - Solution and common mistakes

Step: 4, $k = 2$

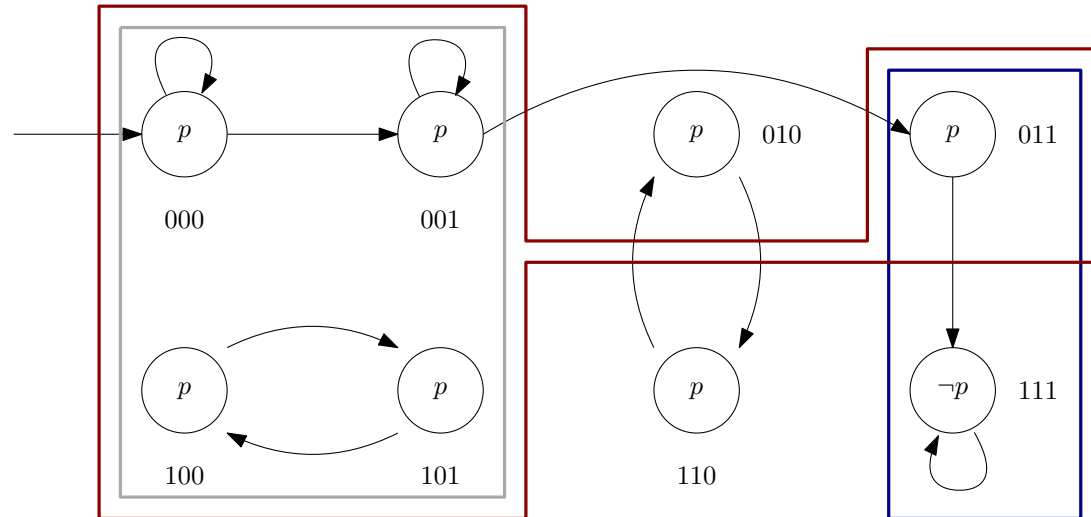

$$Q = \{000, 001, 100, 101\}$$

$$A = Q(s_0) \wedge R(s_0, s_1)$$

$$A = \text{post}(Q) = \{000, 001, 100, 101, 011\}$$

$$B = \bigwedge_{i=1}^{k-1} R(s_i, s_{i+1}) \wedge \bigwedge_{i=1}^k \neg p(s_i)$$

$$B = \{011, 111\}$$

$$\phi = A \wedge B \rightarrow \text{SAT}$$

$$\begin{array}{l} \downarrow \\ Q = S_0? \rightarrow \mathbf{x} \\ \rightarrow k := k + 1 \end{array}$$

Model checking HW3 - Solution and common mistakes

Step: 5, $k = 3$

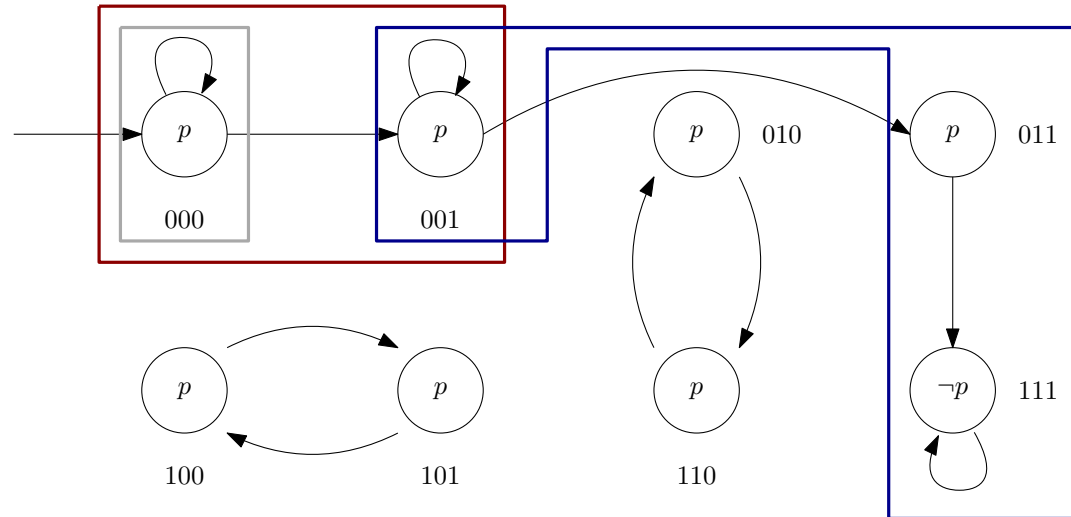

$$Q = \{000\}$$

$$A = Q(s_0) \wedge R(s_0, s_1)$$

$$A = \text{post}(Q) = \{000, 001\}$$

$$B = \bigwedge_{i=1}^{k-1} R(s_i, s_{i+1}) \wedge \bigwedge_{i=1}^k \neg p(s_i)$$

$$B = \{001, 011, 111\}$$

Model checking HW3 - Solution and common mistakes

Step: 5, $k = 3$

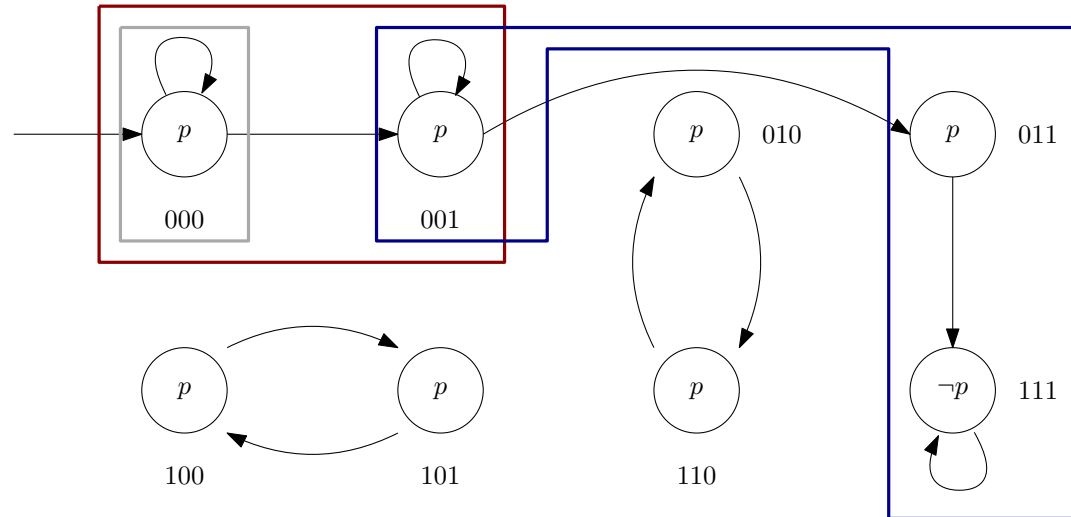

$$Q = \{000\}$$

$$A = Q(s_0) \wedge R(s_0, s_1)$$

$$A = \text{post}(Q) = \{000, 001\}$$

$$B = \bigwedge_{i=1}^{k-1} R(s_i, s_{i+1}) \wedge \bigwedge_{i=1}^k \neg p(s_i)$$

$$B = \{001, 011, 111\}$$

$$\phi = A \wedge B \rightarrow \text{SAT}$$

\downarrow
 $Q = S_0? \rightarrow \checkmark$
 \rightarrow return $M \not\models AG p$

Note: The algorithm finishes here. There is no need to continue to $k = 4$.